

**CATALOGO GENERALE\_PARTE TERZA 3**  
**COLLEZIONI\_0 1 8**

**BESPOKE \_ PANTA REI \_ PIANA \_ ATELIER \_ PLANETA \_ LUNARIA \_ ILBAGNO**

bagnarsi ad arte\_bathing with art



## **CATALOGO GENERALE\_PARTE TERZA COLLEZIONI\_0 1 8**

**[www.antoniolupi.it](http://www.antoniolupi.it)**

Per essere costantemente informati su novità e prodotti in modo dettagliato, vi invitiamo a navigare nel nostro sito sempre aggiornato. Nell'area download potrete scaricare tutto il materiale tecnico ed informativo che vi necessita.

*To constantly be up to date in a detailed manner on novelties and products please navigate through our website. In the download area you can find all the necessary technical information.*



Scarica l'App su App Store e Google Play per entrare nel mondo antoniolupi

*Download the App on App Store and Google Play to discover the world of antoniolupi*

# **antoniolupi**

bagnarsi ad arte\_bathing with art

Collages  
*pensare l'architettura*

Luca Galofaro



INDICE / INDEX

4 - 33  
COLLAGE

34 - 171  
BESPOKE

172 - 267  
PANTA REI

268 - 329  
PIANA

330 - 347  
ATELIER

348 - 373  
PLANETA

374 - 389  
LUNARIA

390 - 451  
ILBAGNO

452 - 455  
FINITURE  
*FINISHES*

456  
INFORMAZIONI ENERGETICHE  
*ENERGETIC INFORMATION*

## COLLAGE design Luca Galofaro

Il fil rouge che lega l'arte al design è ormai un segno distintivo del lavoro che antoniolupi sta sviluppando al suo interno. Più che parlare di contaminazione, vorremmo fare riferimento a due fasi esperienziali diverse che si fondono trovando un obiettivo comune: una esperienza univoca del bello che possa entrare a far parte del quotidiano di ognuno di noi.

Luca Galofaro, Architetto e Professore, da tempo ha concentrato una parte della sua riflessione sulle relazioni esistenti fra rappresentazione, architettura urbana ed immagine.

Attualmente un'ampia sezione dello showroom Pietra e Fuoco della sede di Stabbia di antoniolupi è dedicata ad una Mostra/Collezione di Disegni di Architettura curata da Galofaro stesso: un passo di crescita aziendale di rilievo.

Adesso Galofaro 'contamina' con la propria visione alcuni prodotti della antoniolupi e stringe ancora di più questa collaborazione nata circa un anno fa con Andrea Lupi: alcuni dei Disegni di Architettura facenti parte della Mostra sono stati infatti selezionati ed applicati agli specchi della linea antoniolupi.

L'idea di trasformare alcuni di questi lavori in oggetti di arredo è stata una conseguenza naturale delle riflessioni condivise fra Galofaro ed Andrea Lupi.

Si è trattato di trasformare un'immagine usata per pensare architettura trasferendola su un oggetto d'uso quotidiano, andando a costruire un ponte tra l'immaginazione che domina l'arte e la vita che è solitamente dominata dalla funzione che l'oggetto ha. La tecnica del collage si basa su una sovrapposizione di frammenti. L'immagine nasce come stratificazione di immagini della memoria.

Gli specchi sono realizzati attraverso una stratificazione di lastre in vetro stampate e creano dei collage tridimensionali in cui l'ultimo strato specchiato definisce una relazione con l'osservatore che entra nell'immagine.

"Gli specchi Collage, nascono da un progetto più ampio che in quest'ultimo anno ho condiviso con Andrea Lupi. La costruzione della collezione di disegni di architettura Antonio Lupi. Alcuni dei miei collage sono entrati a far parte della collezione.

L'idea di trasformare alcuni di questi lavori in oggetti di arredo è stata una conseguenza naturale delle nostre riflessioni condivise. Trasformare un'immagine usata per pensare architettura in un oggetto d'uso, un ponte tra l'immaginazione e vita."

(Luca Galofaro)

*The common thread between art and design is now a distinctive sign of antoniolupi's work. More than fusion, we would refer to two different experiences mixed together to achieve a common goal: an univocal experience of beauty that becomes part of our daily life.*

*Luca Galofaro, Architect and Teacher, has focused his attention on relationships between representation, urban architecture and image.*

*An area of the antoniolupi showroom, La Pietra e il Fuoco, in Stabbia is currently hosting an Exhibition/Architecture Drawing Collection curated by Galofaro himself: an important step forward in the company's growth strategy.*

*Now Galofaro 'influences' some of the antoniolupi products with his vision and the collaboration between him and Andrea Lupi is becoming even closer: some Architecture Drawings of the exhibition have been chosen to be used on antoniolupi mirrors.*

*Transforming some of these works in real furniture objects was a natural consequence of the reflection shared by Galofaro and Andrea Lupi.*

*The idea consists of transferring an image used to think of architecture to an item of everyday life, building a bridge between imagination, which dominates art and life, normally dominated by the function of the object. The collage technique is based on overlapping fragments. The image comes from the stratification of images of memory.*

*Mirrors are made overlapping printed glass plates, creating tridimensional collages. The last mirrored layer establishes a relationship with the observer, who becomes part of the image itself.*

*"The Collage mirrors are born from a larger project that I've shared with Andrea Lupi in the past year. The construction of the Antonio Lupi architectural drawings collection. Some of my collages have become part of the collection.*

*The idea of turning some of these works into furnishing objects was a natural consequence of our shared reflections. Transforming an image used to think about architecture into an object of use, a bridge between imagination and life."*

(Luca Galofaro)





# COLLAGE

2 STRATI / 2 LAYERS

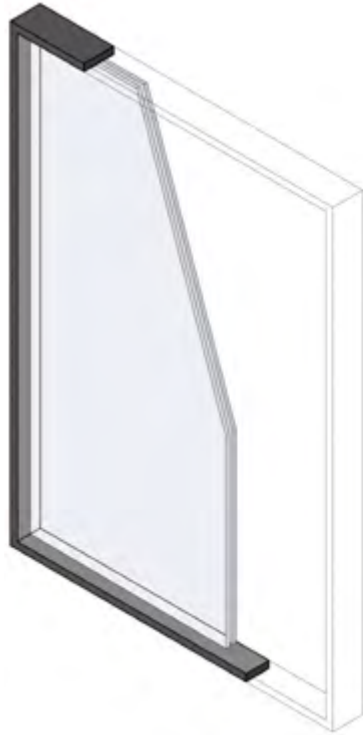

Sono composti da due lastre di vetro inserite in una cornice di alluminio finitura bronzo. La prima lastra è parzialmente argentata a creare la superficie specchiante mentre l'altra sullo sfondo, è stampata con le varie immagini su fondo bianco. La leggera distanza tra i due vetri, lo spessore della cornice è di 4,2 cm, crea un suggestivo effetto di tridimensionalità.

*They consist of two layers of glass inserted in a bronze finish aluminum frame. The first layer is partially mirrored while the other in the background is printed with various images on a white background. The slight distance between the two glasses, the thickness of the frame is 4.2 cm, creates a striking three-dimensional effect.*



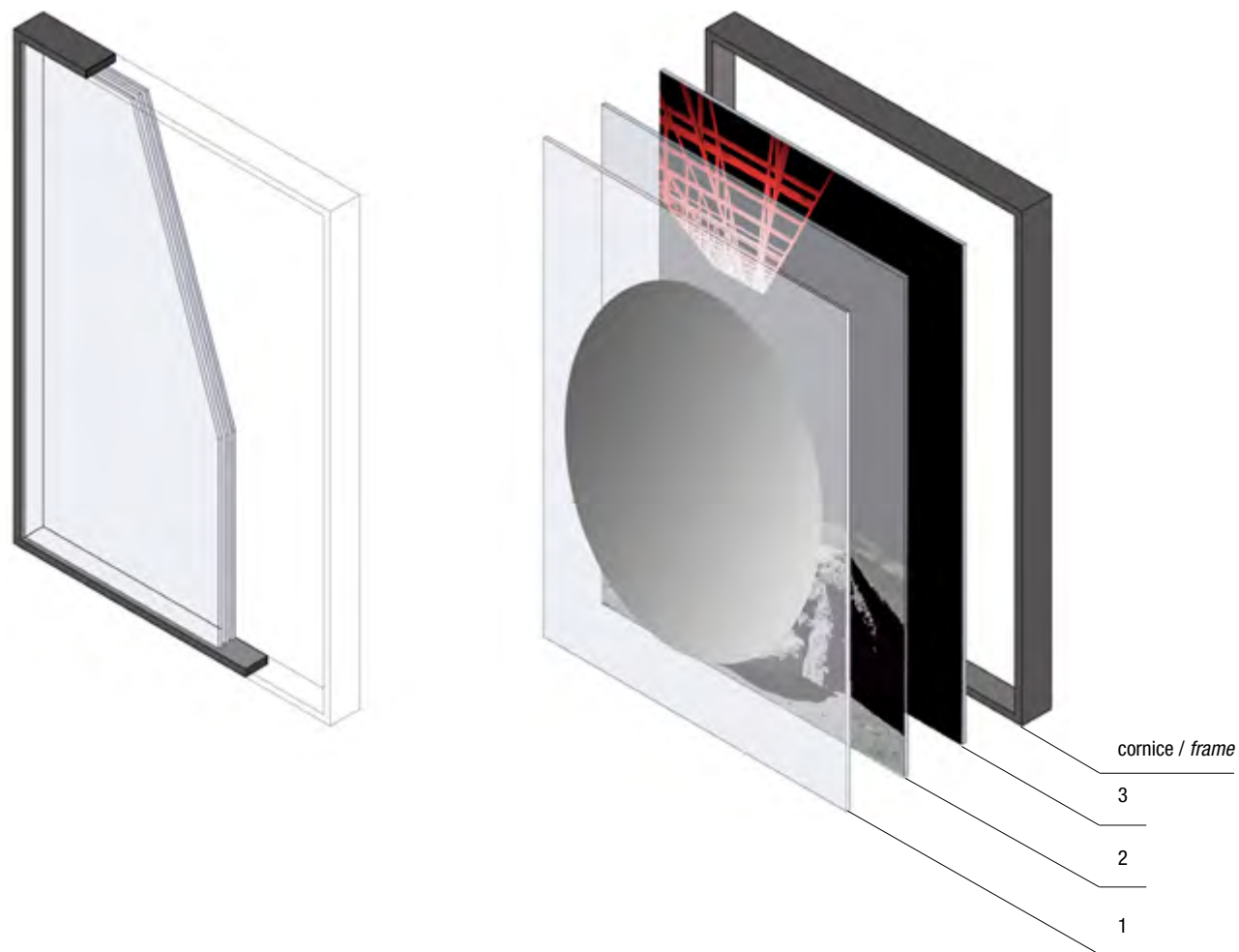

Sono composti da tre lastre di vetro inserite in una cornice di alluminio finitura bronzo. La prima lastra è parzialmente argentata a creare la superficie specchiante, la seconda ospita una stampa parziale su fondo trasparente, mentre la terza, in sequenza, è stampata con una immagine su fondo bianco. La leggera distanza tra i tre vetri, lo spessore della cornice è di 5,4 cm, crea un forte effetto di tridimensionalità.

*They consist of three layers of glass inserted in a bronze finish aluminum frame. The first layer is partially mirrored, the second has a partial print on a transparent background, while the third, in sequence, is a printed image on a white background. The slight distance between the three glasses, the thickness of the frame is 5.4 cm, creates a strong three-dimensional effect.*







art. COLLAGE222 H 108 cm L 36 cm



art. COLLAGE221 H 108 cm L 36 cm



art. COLLAGE318 H 75 cm L 54 cm

COLLAGE



art. COLLAGE307 H 75 cm L 54 cm



art. COLLAGE213 H 90 cm L 70 cm

COLLAGE









art. COLLAGE309 H 75 cm L 54 cm



art. COLLAGE314A H 75 cm L 54 cm

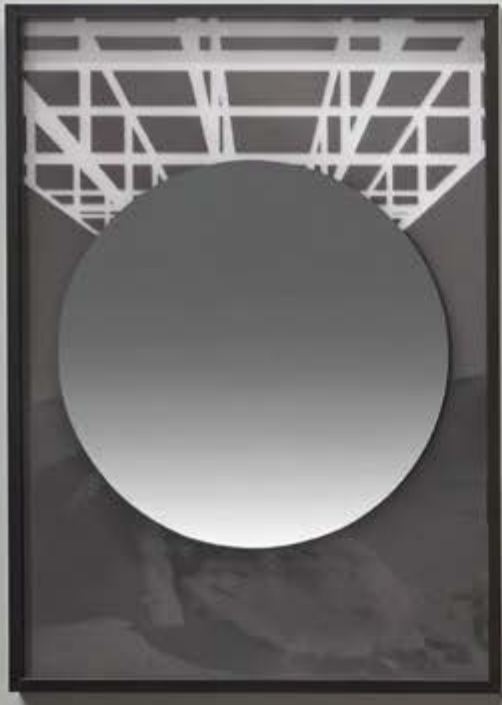

art. COLLAGE314C H 75 cm L 54 cm







art. COLLAGE314B H 75 cm L 54 cm



art. COLLAGE305 H 75 cm L 54 cm



art. COLLAGE227 H 75 cm L 72 cm





art. COLLAGE225 H 75 cm L 72 cm



art. COLLAGE304 H 50 cm L 75 cm



art. COLLAGE303 H 50 cm L 90 cm

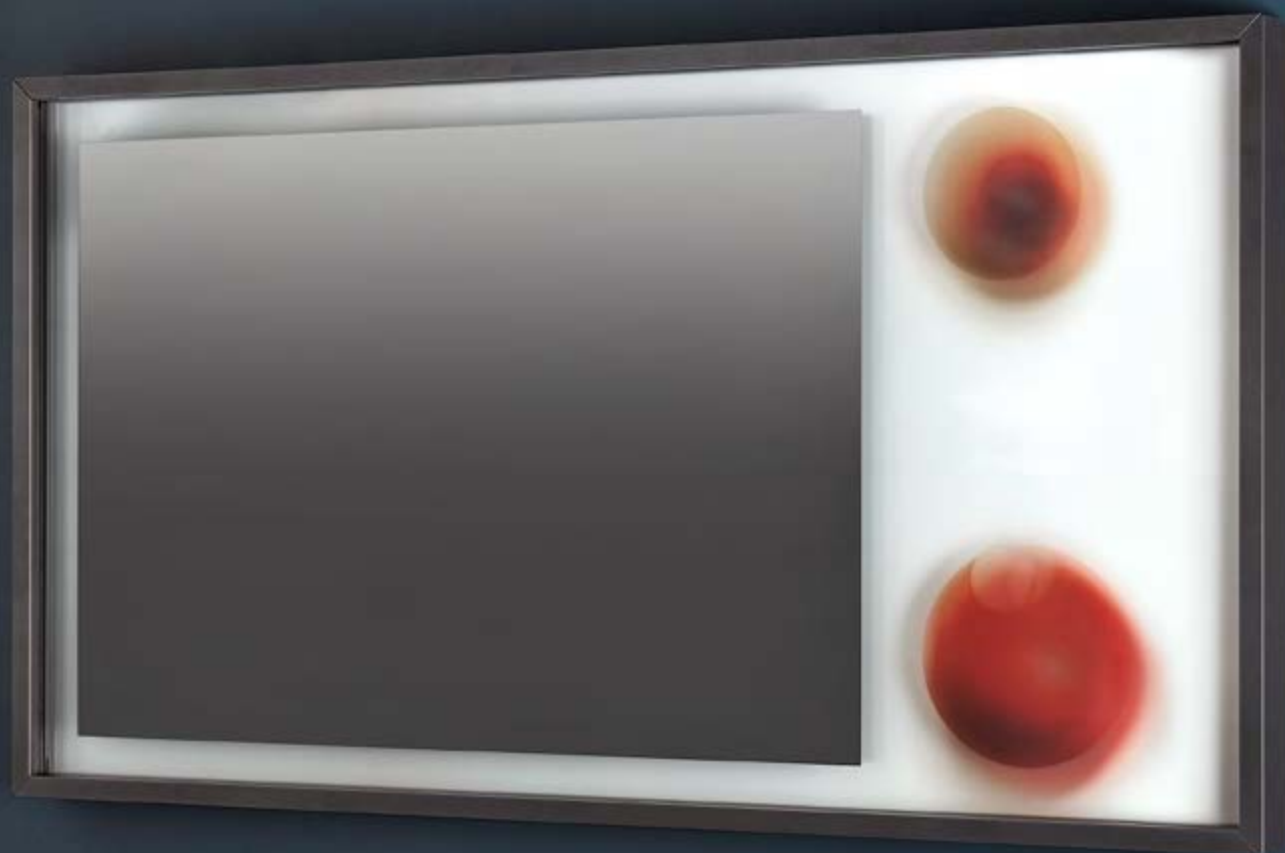

art. COLLAGE308 H 50 cm L 75 cm

COLLAGE



art. COLLAGE212 H 75 cm L 54 cm



art. COLLAGE317 H 75 cm L 108 cm

COLLAGE



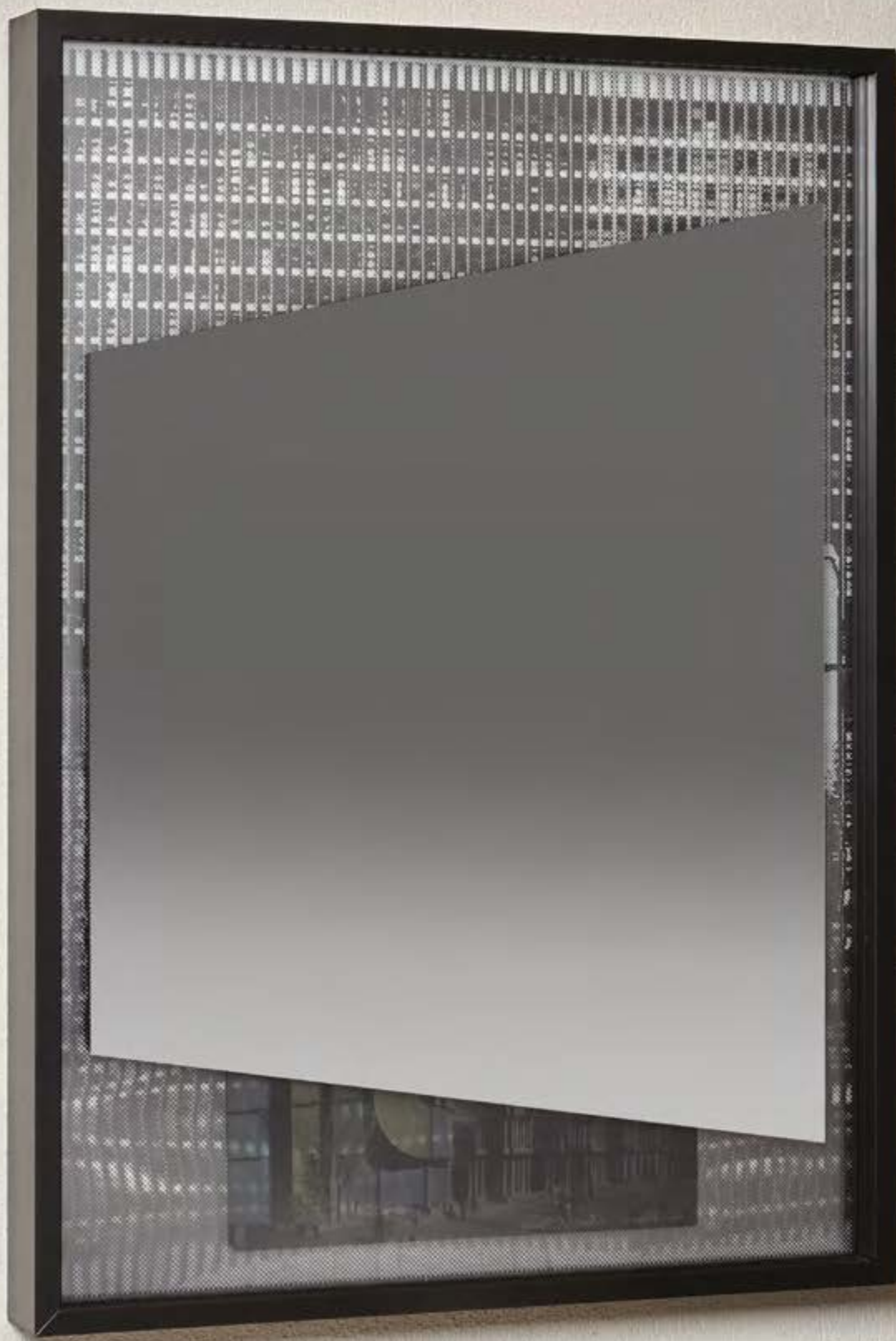



# COLLAGE

2 STRATI / 2 LAYERS

Specchi a 2 strati, di cui uno stampato e l'altro argentato, con cornice in alluminio finitura bronzo.  
*Mirrors with 2 layers, one is printed and one is mirrored, with frame in aluminum bronze finish.*

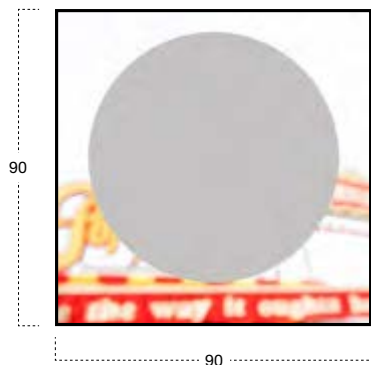

H	L	ART.
90	90	COLLAGE202

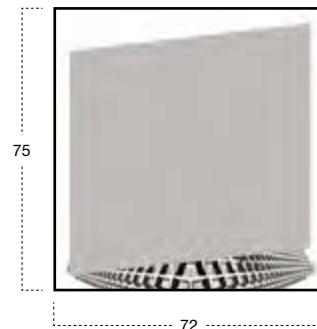

H	L	ART.
75	72	COLLAGE219

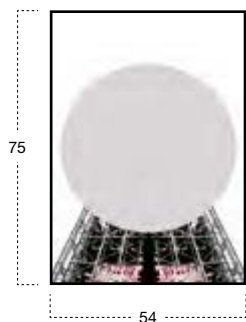

H	L	ART.
75	54	COLLAGE212

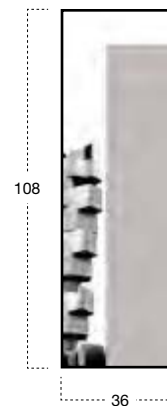

H	L	ART.
108	36	COLLAGE221

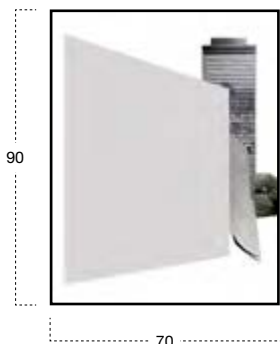

H	L	ART.
90	70	COLLAGE213

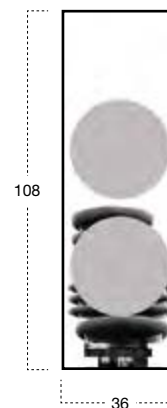

H	L	ART.
108	36	COLLAGE222



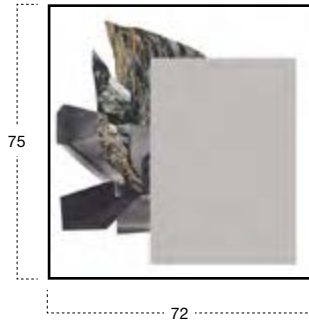

H	L	ART.
75	72	COLLAGE225

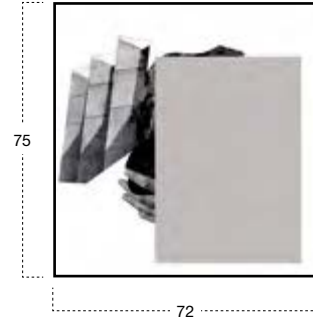

H	L	ART.
75	72	COLLAGE227

3 STRATI / 3 LAYERS

Specchi a 3 strati, di cui due stampati e uno argentato, con cornice in alluminio finitura bronzo.  
 Mirrors with 3 layers, two are printed and one is mirrored, with frame in aluminum bronze finish.

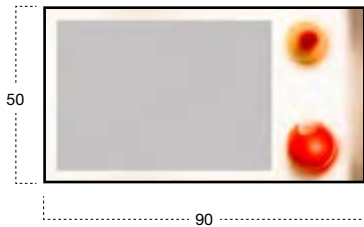

H	L	ART.
50	90	COLLAGE303



H	L	ART.
75	54	COLLAGE306

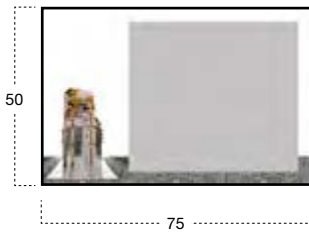

H	L	ART.
50	75	COLLAGE304

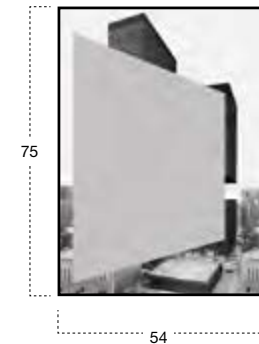

H	L	ART.
75	54	COLLAGE307

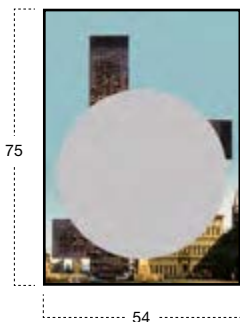

H	L	ART.
75	54	COLLAGE305

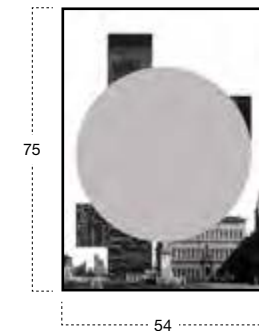

H	L	ART.
75	54	COLLAGE318

# COLLAGE

## 3 STRATI / 3 LAYERS

Specchi a 3 strati, di cui due stampati e uno argentato, con cornice in alluminio finitura bronzo.  
*Mirrors with 3 layers, two are printed and one is mirrored, with frame in aluminum bronze finish.*

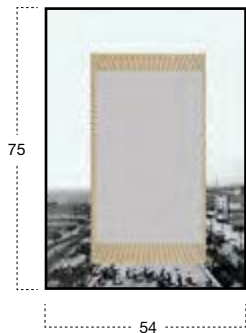

H	L	ART.
75	54	COLLAGE309

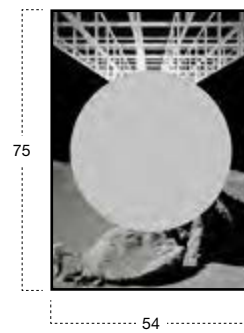

H	L	ART.
75	54	COLLAGE314A

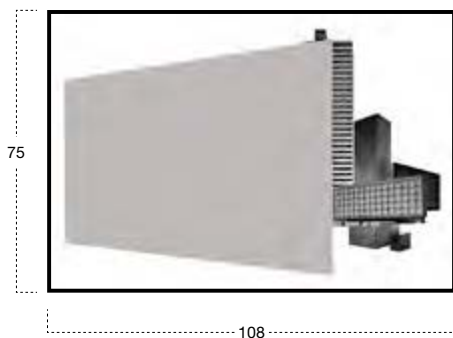

H	L	ART.
75	108	COLLAGE317



H	L	ART.
75	54	COLLAGE314B

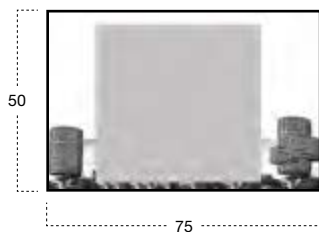

H	L	ART.
50	75	COLLAGE308

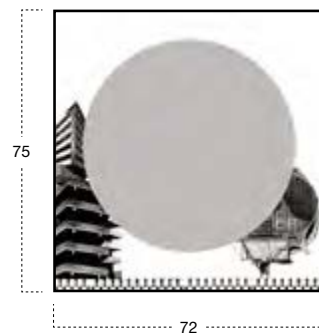

H	L	ART.
75	72	COLLAGE320

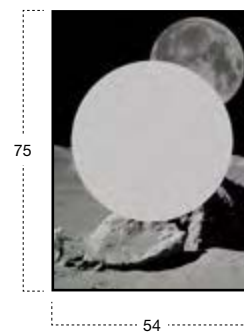

H	L	ART.
75	54	COLLAGE314C



## BESPOKE design Carlo Colombo

Essenziale ma materica, versatile ma elegante, borghese ma contemporanea. Una collezione pensata per l'ambiente bagno ma che ridefinisce i canoni dell'arredo anche nell'area living.

Dettagli tecnologici e formali importanti, elementi funzionali ed estetici che concorrono alla definizione di uno stile. Dalle ante ai piani, dalle maniglie alle cerniere, ogni componente del progetto è pensato per dar vita a un'estetica fatta di dettagli unici e di un perfetto equilibrio compositivo generato da proporzioni perfette, superfici pulite e finiture inedite. Tutto questo è Bespoke, è un sistema d'arredo che porta un messaggio di stile ed eleganza nell'ambiente bagno ma non solo, è un progetto che trasmette allo spazio e a chi lo vive il gusto del bello.

Profili in alluminio satinato e ante in vetro 4mm, disponibili entrambi in diverse finiture, contenitori in essenze ricercate. Ogni materia è espressa nella propria essenza, ogni texture porta valore aggiunto all'insieme, ogni configurazione esprime al meglio la profondità del progetto. Una pluralità di materie che parlano lo stesso linguaggio, accostamenti raffinati che instaurano un dialogo virtuoso tra tutte le superfici.

Basi, porta lavabi, pensili o colonne che possono raggiungere l'altezza massima di 210 cm. Un sistema modulare e versatile che assicura la massima libertà compositiva per dar vita a mobili e contenitori attrezzabili anche con cassetti. Ogni configurazione esprime la capacità di Bespoke di diventare sistema, racconta l'attenzione di antoniolupi nel tradurre l'idea in un progetto organico ed esclusivo, sottolinea la qualità delle lavorazioni e la visione dell'azienda finalizzata a definire uno spazio sartoriale e personalizzato.

*Essential, versatile and elegant, bourgeois yet contemporary. A collection thought for the bathroom but that can easily redefine the living area.*

*Technological and important details, functional and aesthetical elements that define a style. From the fronts to the surfaces and from the handles to the hinges each component of the project is designed to create unique details and a perfect balance of the composition. All of this is Bespoke, a furniture system which brings a message of elegance into the bathroom as well as a project that conveys to space and to those who experience taste for beauty.*

*Brushed aluminum frames and fronts in 4 mm glass, both available in various finishes ; containers in prized essences. Each material is expressed in its essence and each texture adds value to the composition. A plurality of materials that speak the same language refined combinations that establish a virtuous dialogue between all surfaces.*

*Cabinets, sink units, hanging cabinets that can reach a height of 210 cm. A modular and versatile system that ensures maximum freedom in creating compositions. Each configuration expresses the ability to become a system and shows the attention of the company in translating the idea of an exclusive project into a tailored and personalized space.*







La composizione nella foto a destra comprende due specchi NEUTROLED e due specchi NEUTROKIT. Gli specchi NEUTROKIT sono predisposti uno per l'inserimento di rubinetteria AYATI art. AY921LU e art. AY600LU, l'altro per l'inserimento del portasalviette art. RETTA472 colore Malta goffrato. Il mobile è composto da due basi portalavabo art. KILM290 e altre due basi art. KIBM290, colore Grigio Smog opaco, la cornice è in alluminio finitura titanio, il frontale dei cassetti è in vetro acidato fumé. Il top, art. MR147, è in marmo Emperador. I due lavabi da appoggio sono art. SENSO.

Nella foto sopra, particolare di un cassetto con attrezzatura interna DOMINO finitura Noce canaletto.

*The composition in the picture on the right has two mirrors NEUTROLED and two mirrors NEUTROKIT. The mirrors NEUTROKIT are prepared for the tap series AYATI art. AY921LU and art. AY600LU, as well as prepared for the towel bar art. RETTA472 in color embossed Malta. The furniture is made up of two sink units art. KILM290 and two cabinets art. KIBM290 in color matt Grigio Smog. The frame is aluminum with a titanium finish, the fronts are in acid etched smoked glass. The top is in Emperador marble. The two top mount sinks are art. SENSO*

*In the picture above is the detail of the drawer with internal accessories DOMINO in Noce canaletto finish.*

















La composizione a sinistra comprende due specchi NEUTROKIT e due specchi NEUTROLED, rubinetteria AYATI art. AY921LU e art. AY600LU, e una barra porta asciugamani art. RETTA472 colore Malta goffrato. Il mobile è composto da due basi portalavabo art. KILM290 e altre due basi art. KIBM290 di colore Grigio Smog Opaco, da un top in Quarzomood colore Serena, art. QM147 con due lavabi in Flumood art. VERSO e profili in alluminio finitura titanio. I frontali dei cassetti sono in vetro acidato Malta, L'attrezzatura è collezione STRATO con divisori in vetro fumé.

*The composition on the left has two mirrors NEUTROKIT and two mirrors NEUTROLED, AYATI taps art. AY921LU and Art. AY600LU and a towel rail art. RETTA472 embossed lacquered Malta. The furniture is made up of two sink units art. KALM290 and two cabinets art. KIBM290 matt Grigio Smog, has a Quarzomood top color Serena art. QM147 and two top mount sinks in Flumood art. VERSO, while the frames are aluminum titanium. The drawer fronts are in acid glass color Malta. Accesories STRATO with dividers in fumé glass.*



Nelle foto: vasca da bagno in Cristalplant art. BAÍAS con rubinetteria AYATI art. AY903LU e camino art. CANTOMC63 con bruciatore art. LAFLACA. Nella foto a destra sanitari sospesi art. KOMODO3 e art. KOMODO4 in ceramica satinata con rubinetteria AYATI art. AY400LU.

*In the photo: Cristalplant bathtub art. BAÍAS with AYATI tap art. AY903LU and fireplace art. CANTOMC63 with burner art. LAFLACA. In the picture on the right, suspended sanitary-ware art. KOMODO3 and art. KOMODO4 both in satin glaze ceramic with AYATI tap art. AY400LU.*



I quattro pensili, art. KE3490, hanno la struttura color Matita gofrato mentre i profili sono in alluminio finitura bronzo. Le ante sono in vetro argentato fumé.

*The four wall cabinets, art. KE3490 have the carcass lacquered embossed Matita while the frames are in bronze aluminum. The fronts are in silvered fumé glass.*







Questa composizione comprende uno specchio art. NEULUCE1 completo di lampada LUCENTE, rubinetteria INDIGO art. ND301GR, finitura Grafite; il mobile L 216 cm, H 37,5 cm e P 54 cm è composto da una base portalavabo art. KIL2108, da due basi art. KIB254, da un top in Corian art. CR154 con lavabo integrato art. PLATO108, da una struttura Skin cenere con esterni verniciati Grigio Pioggia goffrato. I profili sono in alluminio finitura bronzo, il frontale dei cassetti è in vetro acidato fumé.

*This composition is made up of a mirror art. NEULUCE1 complete with LUCENTE lamp, tap series INDIGO art. ND301GR in the Graphite finish; the furniture is L 216 cm, H 37,5 cm and D 54 cm with a sink unit art. KIL2108 and two cabinets art. KIB254, Corian top art. CR154 with integrated basin art. PLATO108. Structure is in skin cenere with side panels lacquered externally embossed Grigio Pioggia. The aluminum frames are bronze, fronts of the drawers in fumé acid etched glass.*





Questa composizione comprende lo specchio art. COLLAGE213, L 70 cm H 90 cm, rubinetteria INDIGO art. ND200GR, finitura Grafite, un top scatolare in Rovere thermo art. BANCO147, L 216 cm, P 47 cm, H 12,5 cm, su cui è appoggiato un lavabo art. SENSOC in Cristalmood fumé; il mobile L 216 cm, P 47 cm e H 37,5 cm, è composto da tre basi art. KIBM272, e un top in vetro 8 mm art. PT8 Nero acidato. La struttura è Skin cenere, i profili sono in alluminio finitura bronzo, il frontale dei cassetti è in vetro riflettente fumé.

*This composition includes a mirror art. COLLAGE213, L 70 cm H 90 cm, tap series INDIGO art. ND200GR in the Graphite finish a boxy top in Rovere thermo wood art. BANCO147 | 216 cm, D 47 cm, H 12,5 cm with sink art. SENSOC in Cristalmood fumé. The cabinet L 216 cm, D 47 cm, H 37,5 cm is made up of three cabinets art. KIBM272 and a top 8 mm thick acid etched black PT8. The structure is skin cenere and the aluminum frames bronze. The drawer fronts in reflective fumé glass.*









BESPOKE

La composizione nella foto a sinistra, comprende due specchi art. VARIO50W con interruttore art. MAGIC, una coppia di lampade a led art. BOLLA2, rubinetteria BIKAPPA art. BK200N. Il mobile è composto da un top in Quarzomood colore Terra con lavabo integrato art. NIDOQ172, da una struttura in Rovere thermo con profili in alluminio finitura bronzo. Il frontale dei cassetti è in vetro argentato colore bronzo.

*The composition in the photo on the left, has two mirrors art. VARIO50W with switch art. MAGIC, a pair of led lamps art. BOLLA2, BIKAPPA taps art. BK200N. The furniture combination has a Quarzomood top with integrated sink colour Terra art. NIDOQ172, the carcass is in Rovere thermo while the frame in bronze aluminum. The fronts of the drawers are in bronze mirrored glass.*



Cassetto interno opzionale art. SLIM54 e attrezzature STRATO con divisori in fumè glass.

Internal optional drawer art. SLIM54 and accessories STRATO with dividers in fumè glass.



Top in Quarzomood colore Serena.

*Quarzomood top colour Serena.*



Attrezzature STRATO con divisori in vetro fumè.

Accessories STRATO with dividers in fumè glass.



Nelle foto due composizioni, una di L 216 cm ed una di L 180 cm, H 37,5 cm P 54 cm. Il mobile di larghezza L 216 cm, è composto da due basi art. KIB272 e da un porta lavabo art. KIL272. Il top è in Flumood Satin art. BC154, con lavabo integrato art. NIDO, L 216 cm P 54 cm. La seconda composizione è formata da una base di L 90 cm, art. KIB290 e da un porta lavabo L 90 cm, art. KIL290. Il top è in Flumood Satin art. BC154, con lavabo integrato art. NIDO, L 180 cm, P 54 cm. La struttura è in essenza Noce canaletto, il profilo in titanio e il vetro argentato fumé. Gli specchi sono della collezione BESPOKE con cornice in alluminio finitura titanio, art. BSK50W di L 216 cm e H 50 cm e art. BSK50W di L 180 cm e H 50 cm; sopra di essi le lampade art. BOLLA2. La rubinetteria è della collezione BIKAPPA, art. BK200N. All'interno dei cassetti, le attrezzature STRATO, art. SRC5490, per il cassetto di larghezza 90 cm e art. SRC5472, per il cassetto di larghezza 72 cm.

*In the pictures, two compositions, one measuring L 216 cm and one measuring L 180 cm, H 37,5 cm D 54 cm. Furniture measuring L 216 cm is made up of two cabinets art. KIB272 and one sink unit art. KIL272. The top in Flumood satin art. BC154 with integrated sink art. NIDO, L 216 cm D 54 cm. The second composition is made up of a cabinet L 90 cm, art. KIB290 and a sink unit L 90 cm, art. KIL290. The top in Flumood satin art. BC154 with integrated sink model NIDO L 180 cm, P 54 cm. The structure is In wood essence Noce canaletto, frame in titanium and mirrored fumé glass. The mirrors are from the BESPOKE collection art. BSK50W di L 216 cm, H 50 cm and art. BSK50W di L 180 cm, H 50 cm with frames in aluminum titanium finish; lamps art. BOLLA2. BIKAPPA tap series art. BK200N. Inside the drawers STRATO accessories art. SRC5490 for the drawer measuring 90 cm and art. SRC5472 for the drawer 72 cm wide.*







Top in Quarzomood colore Seta

*Quarzomood top colour Seta*



La composizione nella foto comprende uno specchio art. FLASH100W, una coppia di lampade a led art. BOLLA2, rubinetteria BIKAPPA art. BK200N, due barre porta asciugamani art. RETTA490 colore Ovatta goffrato, un termoarredo art. BITL180E colore Ovatta goffrato.

Il mobile è composto da un top con lavabo integrato in Quarzomood colore Seta, art. NIDOQ172, la struttura e i cassetti sono color Ovatta opaco mentre i profili sono in alluminio finitura bronzo. Le ante sono in vetro acidato colore Ovatta.

I due pensili esterni hanno la struttura color Ovatta opaco mentre i profili sono in alluminio finitura bronzo con le ante in vetro Ovatta acidato. Il pensile centrale ha l'anta in vetro trasparente fumé.

*The composition in the photo has a mirror art. FLASH100W, a pair of led lamps art. BOLLA2, tap series BIKAPPA, art. BK200N, two towel rails art. RETTA490 lacquered embossed Ovatta, a radiator art. BITL180E lacquered embossed Ovatta.*

*The cabinet has a Quarzomood top color Seta art. NIDOQ172, the carcass lacquered matt Ovatta while the frame in bronze aluminum. Fronts and drawers are in acid glass colour Ovatta. The two external wall cabinets are in structure Ovatta matt, frame bronze and front in lacquered acid glass Ovatta, while the wall cabinet in the center has the front in transparent fumé glass.*







Attrezzature STRATO con divisori in vetro fumè.

Accessories STRATO with dividers in fumè glass.



La composizione è formata da una base porta lavabo con ante art. KIL5490, una base con doppio cassetto art. KIB472 Ovatta opaco e una base con anta art. KIB5245. La struttura è Ovatta opaco, i profili sono in alluminio finitura champagne, gli altri frontali sono in vetro acidato bronzo. Il top in Flumood Satin L 207 cm, P 54 cm, spessore 12 mm, art. BC154, ospita il lavabo integrato art. NIDO54. Rubinetteria BIKAPPA art. BK200N. Lo specchio art. FLASH100W L 162 cm H 100 cm, è abbinato alla coppia di lampade art. BOLLA2. I 3 pensili art. KE2045 L 45 cm, H 100 cm e P 21,6 cm ciascuno, hanno struttura Ovatta opaco, profili in alluminio finitura champagne; due frontali sono in vetro acidato Ovatta e uno in vetro acidato bronzo. A destra due portasalviette art. RETTA490 Ovatta goffrato L 90 cm ciascuna.



*The composition is made up of a sink unit with doors art. KIL5490, a cabinet with two double drawers art. KIB472 in color matt Ovatta and a cabinet with door art. KIB5245. The structure is matt Ovatta, the frame in aluminum champagne finish, the fronts in bronze acid etched glass. The top is in Flumood satin L. 207 cm, D. 54 cm, 12 mm thick, art.BC154 with integrated sink model NIDO54. Tap series BIKAPPA art. BK200N. The mirror is art. FLASH100W L 162 cm H 100 cm combined with the pair of lamps art. BOLLA2. The 3 wall cabinets art. KE2045 L 45 cm, H 100 cm and D 21,6 cm each, with a matt Ovatta color structure, frame in aluminum champagne finish; two fronts in acid etched glass color Ovatta and one in bronze acid etched glass. On the right two towel bars art. RETTA490 lacquered embossed Ovatta L. 90 each.*





Pianetto in Flumood copri pileta opzionale art. PIANETTO1

Optional Flumood cover plate art. PIANETTO1





I due pensili, art. KE2045, hanno la struttura color Malta opaco, profili in alluminio finitura bronzo e ante in vetro acidato colore Corteccia.

*The two wall cabinets, art. KE2045 with carcass lacquered matt Malta, frame in bronze aluminum and fronts in acid glass color Corteccia.*



Top in Quarzomood color Terra

Quarzomood top colour Terra





La composizione nelle foto comprende due specchi art. NTKIT50W e art. NEUTROLED100W, rubinetteria AYATI art. AY921SA e art. AY600SA, due pensili con struttura color Malta opaco, profili in alluminio finitura bronzo e ante in vetro acidato colore Cortecchia.

Il mobile è composto da un top in Quarzomood colore Terra, art. QM154 con due lavabi in Flumood art. SENSO, la struttura è color Malta opaco mentre i profili sono in alluminio finitura bronzo. I due portalavabi art. KIL290 e la base art. KIB290, sono in vetro acidato colore Cortecchia corredati da attrezzatura STRATO con divisori in vetro fumé.

*The composition in the photo has two mirrors art. NTKIT50W and art. NEUTROLED100W, taps AYATI art. AY921SA and art. AY600SA, two wall cabinets with carcass lacquered matt Malta, frame in bronze aluminum and fronts in acid glass color Cortecchia.*

*The cabinet has a Quarzomood top colour Terra art. QM154 with two sinks in Flumood art. SENSO, the two sink units art. KIL290 and cabinet art. KIB290, is lacquered matt malta while the frames are in bronze aluminum. The drawer fronts are in acid glass color Cortecchia complete with internal accessories STRATO with glass dividers color fumé.*



Lo specchio L 180 cm, H 90 cm, art. VARIO90W, con interruttore art. MAGIC, è corredato da lampade art. BOLLA2. Il mobile, L 180 cm, H 37,5 cm, P 47 cm, è composto da una base con cassetto e da un porta lavabo entrambi di L 90 cm; i profili sono titanio, i vetri Creta acidato e la struttura Creta goffrata. Sopra poggiano il top in vetro acidato Creta art. 947 e il lavabo in Flumood art. SENSO. La rubinetteria è AYATI in finitura satinata art. AY200SA.

*The mirror L 180 cm, H 90 cm art. VARIO90W with switch art. MAGIC and illuminated by the lamp art. BOLLA2. The cabinet L 180 cm H 37,5 cm D 47 cm is made up of a cabinet with single drawer and sink unit L 90 cm; the profiles are in titanium the acid glass lacquered Creta and the carcass lacquered embossed Creta. The top is in acid glass lacquered Creta art. 947 and the sink is in Flumood art. SENSO. AYATI tap art. AY200SA in the satin finish.*



Attrezzature STRATO con divisori in vetro fumè.

Accessories STRATO with dividers in fumè glass.





**Su richiesta:**

Una serie di colonne con profilo titanio, vetro Creta acidato e struttura Skin cenere; due sono con doppia anta, L 108 cm e una con anta singola, L 54 cm; tutte sono H 210 cm e P 47 cm.

**Upon request:**

A series of high cabinets with titanium profile acid glass lacquered Creta and carcass in the Skin cenere finish; two are with double doors L 108 cm and the other single door; all are H 210 cm and 47 cm D.



La composizione comprende a sinistra una colonna art. KC3472, struttura Rovere thermo con profili in alluminio finitura bronzo, ante in vetro argentato bronzo. Specchio art. BSK50W sul quale è stata inserita una coppia di lampade art. BOLLA2 con profili in alluminio finitura bronzo. Sotto lo specchio una mensola da incasso a parete con struttura in alluminio nero con illuminazione a led, art. OMBRAL di L 90 cm con portasalviette art. OMBRAP36. Il mobile è composto da una base portalavabo art. KIL290 e da una base art. KIB290 entrambe con struttura Rovere thermo con profili in alluminio finitura bronzo, ante in vetro argentato bronzo. Il lavabo in Flumood è l'art. SENSO, mentre la rubinetteria della serie AYATI è in acciaio satinato art. AY921SA e art. A600SA. Il top è in marmo Emperador, art. MR154.



*The composition is made up of a column on the left at. KC3472, structure in Rovere thermo and frame in bronze aluminum finish, fronts in bronze silvered glass.*

*Mirror art. BSK50W and pair of lamps art. BOLLA2 with a bronze aluminum frame. Under the mirror is an encased shelf with a black aluminum frame and led lighting, art. OMBRAL L 90 cm and towel bar art. OMBRAP36. The composition is made up of a sink unit art. KIL290 and a cabinet art. KIB290 both with structure in Rovere thermo and frame in bronze aluminum, fronts in bronze silvered glass. The sink in Flumood is art. SENSO while the tap is from the AYATI series in satin stainless steel art. AY921SA and art. A600SA. The top is in Emperador marble art. MR154.*









In questa composizione in alto sono posizionati due specchi art. VARIO50W con illuminazione a led più coppia di lampade art. BOLLA2. Sotto troviamo una mensola da incasso a parete con struttura in alluminio nero con illuminazione a led, art. OMBRAL di L 108 cm con portasalviette art. OMBRAP36. Il mobile è composto da una base portalavabo art. KIL290 e da una base art. KIB290 entrambe con struttura Skin cenere con profili in alluminio finitura titanio, ante in vetro argentato fumé. Il top in Flumood finitura Satin con lavabo integrato art. NIDO mentre la rubinetteria della serie AYATI è in acciaio satinato art. AY921SA e art. AY600SA.

I sanitari sono art. KOMODO3 e art. KOMODO4 con rubinetteria AYATI art. AY400SA. Sopra e a lato dei sanitari sono posizionati una placca art. ONDA in acciaio satinato e un idroscopino con porta carta art. CARTATENSO sempre in acciaio satinato.



*In the composition above are positioned two mirrors art. VARIO50W with led lighting and pair of lamps art. BOLLA2. Below an encased frame with structure in black aluminum and led lighting art. OMBRAL with towel rail art. OMBRAP536. The cabinet is made up of a sink unit art. KIL290 and of a cabinet art. KIB290 both with structure in Skin cenere and frame in aluminum with a titanium finish, fronts in smoked silvered glass. The top is in Flumood Satin finish with integrated basin art. NIDO while the tap series is AYATI in satin stainless steel art. AY921SA and art. AY600SA.*

*The sanitary-ware is art. KOMODO3 and art. KOMODO4 with AYATI tap art. AY400SA. Above and next to the sanitary-ware are the flush plate in satin stainless steel art. ONDA and a hydrobrush with paper towel holder art. CARTATENSO in satin stainless steel.*





Attrezzatura DOMINO in finitura Noce canaletto.

Internal accessories DOMINO in Noce canaletto wood finish.



Vetro riflettente fumé  
Reflective fumé glass



Vetro acidato bronzo

Bronze acid glass

La composizione è formata da una base con cassetto, art. KIB236, L 36 cm H 37,5 cm P 54 cm, da un porta lavabo con cassetto art. KIL2108 L 108 cm, H 37,5 cm, P 54 cm, e da una base con cassetto L 54 cm, H 37,5 cm, P 54 cm, art. KIB254. La struttura dell'intera composizione è Rovere thermo, il telaio in alluminio finitura zirconio, il vetro delle ante è acidato bronzo. Lo specchio con illuminazione a led, art. CIRCUS140W, è Ø 140 cm. Il top in Corian, art. CR154, L 198 cm, P 54 cm ha lavabo integrato art. OPENSLOT108. La rubinetteria appartiene alla collezione AYATI ed è in finitura lucida, art. AY921LU e art. AY600LU.

*The composition is made up of a cabinet art. KIB236, L 36 cm H 37,5 cm D 54 cm, a sink unit with drawer art. KIL2108 L 108 cm, H 37,5 cm, D 54 cm, and a cabinet with drawer L 54 cm, H 37,5 cm, D 54 cm, art. KIB254. The entire structure is in Rovere thermo, frame in aluminum with a zirconium finish, the glass fronts are bronze acid etched. The mirror with led lighting is art. CIRCUS140W, Ø 140 cm. The top in Corian art. CR154, L 198 cm, D 54 cm with integrated sink art. OPENSLOT108. Tap series AYATI in a polished finish art. AY921LU and art. AY600LU.*



La composizione è formata da una base con anta, art. KAB5236, L 36 cm H 50 cm P 54 cm, da un porta lavabo con doppia anta L 108 cm, H 50 cm, P 54 cm, art. KAB54108, e da una base con doppia anta L 72 cm, H 50 cm, P 54 cm, art. KAB5472. La struttura dell'intera composizione è Skin cenere, il telaio in alluminio finitura titanio, il vetro delle ante è trasparente fumé. Lo specchio con illuminazione a led, art. FLASH75W, è L 216 cm, H 75 cm. Il top L 216 cm, H 75 cm in Flumood finitura Texture, art. BC154 con lavabo integrato art. PODIO, è completo di copripiletta art. PIANETTO. La rubinetteria appartiene alla collezione AYATI ed è in finitura lucida, art. AY921LU e art. AY600LU.

*The composition is made up of a cabinet with single door art. KAB5236, L 36 cm H 50 cm D 54 cm, a sink unit with double doors measuring L 108 cm, H 50 cm, D 54 cm, art. KAB54108 and a cabinet with double doors L 72 cm, H 50 cm, D 54 cm, art. KAB5472. Structure in Skin cenere, frame in aluminum titanium finish and transparent fumé glass. The mirror with LED lighting art. FLASH75W, L 216 cm, H 75 cm. Top in Flumood Texture finish art. BC154 with integrated sink art. PODIO, is complete with cover plate art. PIANETTO. AYATI tap series polished finish art. AY921LU and art. AY600LU.*





Vetro trasparente fumé

Transparent fumé glass



Vetro acidato fumé

*Fumé acid glass*



Vetro acidato Matita

Laquered Matita acid glass









Nella foto a sinistra sugli specchi art. NEUTRO1180W45, L 45 cm, H 180 cm, sono inserite le lampade art. LUCENTE45. La composizione è formata da due porta lavabi art. KILM290, L 90 cm, H 37,5 cm, P 47 cm e da una base L 90 cm, H 37,5 cm, P 47 cm, art. KIBM290. La rubinetteria AYATI da piano è in finitura satinata, art. AY303SA. I due lavabi sono in Flumood art. VERSO. I due pensili, art. ICE4, L 27 cm, H 25 cm, P 14 cm e art. ICE6, L 72 cm, H 25 cm, P 14 cm, hanno lo schienale verniciato Meringa gofrato e il vetro bronzo. L'intera composizione ha la struttura Bianco Mood gofrato; il telaio dei cassetti è in alluminio finitura bronzo e il frontale Meringa acidato. Il top art. BC147 è in Flumood finitura Satin.

La composizione nella foto in alto ha la variante dei lavabi in Flumood art. STRATOS1.

*In the picture on the left the mirrors art. NEUTRO1180W45, L 45 cm, H 180 cm are the lamps art. LUCENTE45. The composition is made up of two sinks units art. KILM290 L 90 cm, H 37,5 cm, D 47 cm and cabinet L 90 cm, H 37,5 cm, D 47 cm, art. KIBM290. The AYATI tap is art. AY303SA in a satin stainless steel finish. The two sinks are in Flumood art. VERSO. The two wall cabinets art. ICE4, L 27 cm, H 25 cm, D 14 cm and art. ICE6, L 72 cm, H 25 cm, D 14 cm, the backs are lacquered embossed Meringa and the glass is bronze. The entire composition has the structure embossed Bianco Mood; the frames of the drawers are bronze aluminum and fronts in acid lacquered Meringa. The top art. BC147 is in Flumood satin finish.*

*The composition above has the variant of sinks in Flumood art. STRATOS1.*



Attrezzatura DOMINO in finitura  
Noce canaletto. Top in Quarzomood  
colore Seta.

*Internal accessories DOMINO in Noce  
canaletto wood finish.  
Quarzomood top colour Seta.*





BESPOKE







La composizione è formata da uno specchio art. NEUTRO1180W45, L 45 cm, H 180 cm, sopra la lampada art. BOLLA1. Sul top, art. BANCO154, in essenza Rovere evaporato, L 180 cm, H 12,5 cm, P 54 cm, poggia il lavabo in Flumood art. SENSO. La rubinetteria AYATI da parete è in finitura satinata, composta da art. AY921SA e da art. AY600SA. Sotto il top, il mobile L 270 cm, è composto da tre basi art. KBB290, ognuna L 90 cm, H 25 cm, P 54 cm. La struttura è Pomice opaco, i profili sono in alluminio finitura bronzo e le ante in vetro acidato Pomice. Il top di finitura, art. IT21, è in legno laccato color Pomice opaco. All'interno le attrezzature STRATO art. SRC5490. I due pensili, art. ICE4, L 27 cm, H 25 cm, P 14 cm e art. ICE6, L 72 cm, H 25 cm, P 14 cm, hanno lo schienale verniciato Creta opaco e il vetro fumé. I portasalviette sono di larghezza L 72 cm, art. RETTA472 Creta goffrato.

*The composition is made up of a mirror art. NEUTRO1180W45, L 45 cm, H 180 cm, above lamp art. BOLLA1. Top art. BANCO154 in Rovere evaporato, L 180 cm, H 12,5 cm, D 54 cm and Flumood sink art. SENSO. AYATI tap series in satin finish art. AY921SA and art. AY600SA. Under the top furniture L 270 cm, three cabinets art. KBB290, each L 90 cm, H 25 cm, D 54 cm and finishing top art. IT21. The structure in matt Pomice, frame in aluminum bronze finish and fronts in acid glass lacquered Pomice. Internal drawer accessories STRATO art. SRC5490. The two wall cabinets art. ICE4, L 27 cm, H 25 cm, D 14 cm and art. ICE6, L 72 cm, H 25 cm, P 14 cm, are lacquered matt Creta and fumé glass. Towel rails L 72 cm, art. RETTA472 lacquered embossed Creta.*





Lo specchio art. VERTICE75W è di L 144 cm, H 75 cm, il top scatolare in Flumood Satin art. BCS54, L speciale 288 cm, P 54 cm, H 12,5 cm ospita due lavabi art. NIDO. In basso un top scatolare art. BANCO154 in Rovere thermo delle stesse dimensioni. La rubinetteria è AYATI in finitura satinata art. AY921SA e art. AY600SA.

Il camino a bioetanolo è un art. CANTOMC63 con inserito il bruciatore art. LAFLACA.

*The mirror art. VERTICE75W is L 144 cm, H 75 cm; the top in FLUMOOD satin art. BCS54, special L 288 cm, D 54 cm, H 12,5 cm with two integrated basins art. NIDO. Below a boxy top art. BANCO154 in Rovere thermo of the same length. AYATI tap series in satin stainless steel art. AY921SA and AY600SA.*

*The bioethanol fireplace is art. CANTOMC63 with burner art. LAFLACA.*









Il mobile è formato da 3 basi con cassetto Art. KIBM272, struttura Matita goffrato, profili in alluminio finitura bronzo, frontali in vetro riflettente fumé. Il top art. PT8 è in vetro acidato Matita di dimensioni L 216 cm, P 47 spessore 8 mm. Sopra il mobile, due colonne a giorno in vetro trasparente fumé art. ICE2, con schienale Matita goffrato. Il lavabo è l'art. CANALE in Flumood L 216 cm, P 47 cm, H 12,5 cm. Sopra il lavabo, due specchi NEUTROKIT; uno predisposto per l'inserimento della rubinetteria AYATI art. AY921SA e art. AY600SA, l'altro per l'inserimento del portasalviette art. RETTA454.

*The furniture is made up of 3 cabinets with drawer art. KIBM272, structure embossed Matita, frames in bronze aluminum, fronts in reflective smoked glass. The top art. PT8 is acid etched lacquered Matita L 216 cm, D 47 and 8 mm thick. Above the furniture two open cabinets in smoked glass art. ICE2 with back panel lacquered embossed Matita. The sink is art. CANALE in Flumood L 216 cm, D 47 cm, H 12,5 cm. Above the sink two mirrors NEUTROKIT. One of the mirrors is prepared for the AYATI taps art. AY921SA and art. AY600SA, the other is prepared for the towel bar art. RETTA454.*



Vetro laccato acidato Matita.

Laquered Matita acid glass.

In queste immagini la composizione illustrata nella pagina precedente, presenta la variante del top scatolare in Flumood finitura Satin art. BCS47 di L 216 cm, P 47 cm, H 12,5 cm, sul quale poggia il lavabo in Flumood art. SIMPLOVALE.

*In this image the composition from the previous page presents an alternative of the boxy top in satin Flumood art. BCS47 measuring L 216 cm, P 47 cm, H 12,5 cm with top mount sink art. SIMPLOVALE.*



Vetro riflettente fumé  
*Reflective fumé glass*



Composizione formata da tre specchi: art. NEUTROLED75W speciale in larghezza L 178 cm, H 75 cm - art. NTKIT50W predisposto per rubinetteria, speciale in larghezza L 178 cm, H 50 cm - art. NEUTROLED50W L 90 cm H 50 cm. La rubinetteria da parete collezione AYATI, è composta da art. AY921LU e art. AY600LU, mentre quella da piano è l'art. AY301LU. Il mobile, è composto da tre basi con cassetto, L 90 cm, H 25 cm, P 54 cm, art. KBB290; la struttura è color Pomice opaco, i profili dei cassetti sono in alluminio finitura titanio e i frontali sono in vetro acidato Pomice. Anche il top di finitura, è color Pomice goffrato, art. IT21. Sopra il top art. BCS54 in Flumood finitura Satin, i lavabi art. SIMPLOTONDO e art. SIMPLO42. All'interno del cassetto, l'attrezzatura STRATO art. SRC5490. Il pensile, con doppia anta, art. KE3790, ha la struttura e i profili come il mobile, mentre il vetro delle ante è trasparente fumé.

*Composition made up of three mirrors art. NEUTROLED75W special in length L 178 cm, H 75 cm, - art. NTKIT50W prepared for tap special in length L 178 cm H 50 cm - art. NEUTROLED50W L 90 cm H 50 cm. AYATI tap series art. AY921LU and art. AY600LU, mixer tap is art. AY301LU. Furniture from the BESPOKE collection made up of three cabinets with drawers L 90 cm, H 25 cm, P 54 cm, art. KBB290; structure and finishing top art. PT21 lacquered matt Pomice, frames in aluminum titanium finish and fronts in acid glass lacquered Pomice. Top art. BCS54 in satin Flumood, sinks art. SIMPLOTONDO and art. SIMPLO42. Inside the drawer accessories STRATO art. SRC5490. The wall cabinet with double doors art. KE3790 has the structure and frames as the furniture while the glass is transparent fumé.*





Sopra, il top art. BCS54 in Flumood finitura Satin, è predisposto per lavabo art. SIMPLOTONDO con rubinetteria AYATI in appoggio art. AY301LU e per il lavabo art. SIMPLO42 con rubinetteria su specchio art. AY921LU e art. AY600LU.

*Top art. BCS54 in Satin Flumood is prepared for sink art. SIMPLOTONDO, with top mount mixer art. AY301LU and for sink art. SIMPLO42 with mixer in the mirror art. AY921LU and art. AY600LU.*





I lavabi in Cristalplant art.TUBA3, si completano con la rubinetteria AYATI in finitura lucida art. AY902LU. Gli specchi con illuminazione a led e cornice titanio art. BSK210W90, sono di L 90 cm, H 210 cm, .

*The sinks are in Cristalplant art. TUBA3 and AYATI tap series art. AY902LU polished. The mirrors with LED lighting have a frame in aluminum titanium finish art. BSK210W90 L 90 cm, H 210 cm.*





Sopra, due pensili L 90 cm, H 50 cm, P 21,6 cm, art. KE3490, struttura Matita opaco, profili in alluminio finitura bronzo e ante in vetro argentato fumé. Sotto, sanitari in finitura satinata, art. KOMODO3 e art. KOMODO4 con rubinetteria AYATI in finitura lucida art. AY400LU. Sono in finitura lucida anche la placca di comando art. ONDA e gli accessori della collezione PLAY.

*Above, two wall cabinets L 90 cm, H 50 cm, P 21,6 cm, art. KE3490, structure in matt Matita, frame in aluminum bronze finish and fronts in transparent fumé glass. Below, sanitary ware art. KOMODO3 and art. KOMODO4 in a matt finish with AYATI tap series art. AY400LU polished as is art. ONDA flushing plate and the PLAY accessories series.*



Nella foto sopra, quattro pensili con illuminazione a led art. MANTRA250, ognuno di L 90 cm, H 50 cm, P 14,7 cm colore Bianco Vetro goffrato. I due lavabi sono in Flumood, art. FUSTO, corredati di porta salviette art. FOLDVE, il tutto verniciato Creta goffrato. Di lato ai lavabi, il mobile con struttura Bianco Vetro goffrato, profilo in titanio e vetro trasparente fumé, è composto da due basi con doppia anta e da un ripiano interno, art. KABM5490, L 180 cm, H 50 cm di profondità speciale. Anche il top di finitura è in legno laccato Bianco Vetro goffrato, art. ITM21; la rubinetteria è della collezione AYATI, art. AY200SA.

Nella foto a destra della stessa composizione, le ante sono in vetro cannettato trasparente, mentre il top è realizzato in Quarzomood colore Serena. A fianco due lavabi art. VENERE con rubinetteria della collezione AYATI, art. AY200SA e sifone in acciaio satinato art. MICRO.



*In the photo above, four wall cabinets with LED lighting art. MANTRA250 L 90 cm, H 50 cm, D 14,7 cm lacquered embossed Bianco Vetro. Sinks in Flumood art. FUSTO with towel rail art. FOLDVE both lacquered embossed Creta. Cabinets with double doors and internal shelf have the structure lacquered embossed Bianco Vetro, frame in aluminum titanium and fronts in transparent fumé glass art. KABM5490, L 180 cm, H 50 cm, in a custom depth. Finishing top is lacquered embossed Bianco Vetro art. BST47; AYATI tap series art. AY200SA.*

*On the right page, the same composition has the fronts ribbed transparent glass while the top is in Quarzomood satin color Serena. To the side two sinks art. VENERE with AYATI tap art. AY200SA and siphon in satin stainless steel art. MICRO.*



Vetro cannettato trasparente

*Ribbed clear glass*



Vetro cannettato trasparente

*Ribbed clear glass*



Frontali delle ante in vetro cannettato trasparente.

*Doors in ribbed clear glass.*



BESPOKE







La composizione comprende due specchi art. LUXOR1, due lampade art. BOLLA1, una mensola da incasso a parete con struttura in alluminio nero con illuminazione a led, art. OMBRAL con 2 portasalviette art. OMBRAP36. La rubinetteria è della serie AYATI art. AY921SA con miscelatori MAYDAY verniciato rosso. I due lavabi in Flumood sono art. VENERE con sifone MICRO in acciaio satinato. Il mobile è art. KIBM2108 struttura colore Bianco Mood goffrato con telaio in alluminio finitura bronzo, frontale in vetro acidato colore Bianco Mood. La composizione comprende un cassetto opzionale art. SLIM40 e un'attrezzatura DOMINO finitura noce canaletto. La vasca in primo piano art. EDONIA è completata dal rubinetto AYATI art. AY903SA.

*The composition has two mirrors art. LUXOR1, two lamps art. BOLLA1, an encased shelf with black aluminum structure and led lighting art. OMBRAL, two towel rails art. OMBRAP36. The tap series is AYATI art. AY921SA with MAYDAY mixer lacquered red. The two sinks in Flumood are art. VENERE with MICRO siphon in satin stainless steel. The cabinet is art. KIBM2108 with structure lacquered embossed Bianco Mood with frame in bronze aluminum and fronts in acid etched lacquered glass color Bianco Mood. The composition consists of an optional drawer art. SLIM40 and internal accessories DOMINO in Noce canaletto. The bathtub is art. EDONIA complete with the AYATI tap series art. AY903SA.*



Sopra, due composizioni uguali composte da: un lavabo con illuminazione a led, art. STRAPPOL, con rubinetteria AYATI in finitura satinata, art. AY920SA e art. AY600SA, da uno specchio, L 108 cm, H 120 cm, art. NTKIT125W speciale in altezza e predisposto per la rubinetteria. Lo specchio è illuminato dalla lampada art. BOLLA1. Le colonne sono di uguale altezza e profondità, H 210 cm, P 21,6 cm, ma di due larghezze diverse, L 36 cm e L 54 cm. Per quella di larghezza L 36 cm, la struttura è Cipria goffrato, il profilo in alluminio finitura titanio e il vetro trasparente fumé. La più grande, si differenzia dalla piccola nel colore del vetro, che in questo caso è Cipria acidato. I pensili art. ICE6, sono L 72 cm, P 14 cm, H 25 cm, lo schienale è colore Cipria lucido mentre il vetro è fumé.



Above, two identical compositions: a sink with LED lighting art. STRAPPOL, AYATI tap series in satin finish art. AY920SA and art. AY600SA, mirror L 108 cm, H 120 cm, art. NTKIT125W custom in height and prepared for taps. The mirror is lit by lamps art. BOLLA1. High cabinets are the same height and depth H 210 cm, D 21,6 cm but of different width, L 36 cm and L 54 cm. The smaller having a structure lacquered embossed Cipria and frame in aluminum titanium finish and transparent fumé glass while the larger has a different color glass, acid lacquered Cipria. The wall cabinets art. ICE6 L 72 cm, D 14 cm, H 25 cm have a back panel lacquered glossy Cipria while the glass is fumé.















Nella foto in alto i due specchi con illuminazione a led della collezione BESPOKE art. BSK210W90 di L 90 cm, H 210 cm con cornice in alluminio finitura titanio. A sinistra in basso, due top in essenza Rovere thermo uno di L 216 cm, ed uno di L 180 cm, H 12,5 cm, P 54 cm, art. BANCO154.

Sopra i top, due lavabi in Flumood art. URNAMOOD con rubinetteria AYATI in finitura lucida, art. AY600LU e art. AY921LU. Il mobile è formato da tre basi speciali con cassetto, L 108 cm, H 37,5 cm, P 47 cm, per una larghezza totale di L 324 cm. La struttura è Skin cenere, i profili sono in alluminio finitura titanio e i frontali sono in vetro acidato fumé.

*In the photo above the two mirrors with led lighting from the BESPOKE collection art. BSK210W90, L 90 cm, H 210 cm with frame in aluminum titanium finish. On the left below two tops in wood essence Rovere thermo one measuring L 216 cm, and the other L 180 cm, H 12,5 cm, D 54 cm art. BANCO154.*

*On the top two sinks in Flumood art. URNAMOOD with tap series AYATI in a polished finish art. AY600LU and art. AY921LU. The furniture is made up of three custom cabinets, L108 cm H 37,5 cm, D 47 cm, for a total length of L 324 cm. The structure is in Skin cenere, frame in aluminum titanium finish and fronts are in acid etched fumé glass.*





Le colonne con doppia anta, art. KC39108, L 108 cm, H 175 cm P 47 cm hanno la struttura Skin cenere, i profili delle ante in alluminio finitura titanio e i frontali in vetro argentato fumé.

*Columns with double doors art. KC39108, L 108 cm, H 175 cm D 47 cm have the structure In Skin cenere, frame of doors in aluminum titanium finish and fronts in mirrored fumé glass.*







La vasca è in Cristalplant art. DAFNE, con rubinetteria AYATI art. AY903SA, termoarredo BITLIGHT art. BITL120E, L 45 cm, H 120 cm, Pomice goffrato. Le colonne, con struttura Skin cenere e profili in alluminio finitura titanio, sono tutte di uguale altezza e profondità, H 150 cm, P 47 cm; quattro sono di larghezza L 36 cm, art. KC1636, due con frontale in vetro trasparente fumé e due con vetro argentato fumé. L'ultima colonna di destra, art. KC3672, L 72 cm è composta da due ante di L 36 cm, il frontale è in vetro acidato fumé.

*The bathtub in Cristalplant art. DAFNE and AYATI tap series art. AY903SA, BITLIGHT radiator art. BITL120E, L 45 cm, H 120 cm, lacquered embossed Pomice. The high cabinets with structure in Skin cenere and frame in aluminum titanium finish, H 150 cm, P 47 cm; four L 36 cm, art. KC1636, two glass fronts transparent fumé and two mirrored fumé glass. The last high cabinet on the right art. KC3672, L 72 cm double doors in acid fumé glass.*





Frontali delle ante in vetro cannettato trasparente.

*Doors in ribbed clear glass.*









Vasca in Cristalplant L 200 cm, P 140 cm, H 55 cm, art. SARTO MAXI2

*Cristalplant bathtub* L 200 cm, P 140 cm, H 55 cm, art. SARTO MAXI2





BESPOKE

Composizione formata da uno specchio su misura, da un top in Corian, L 216 cm, H 12,5 cm P 54 cm, art. CRS54 con lavabi integrati art. MYSL0T72. La rubinetteria della serie AYATI in finitura satinata, art. AY921SA e art. AY600SA. Il mobile, della collezione BESPOKE, è composto da tre basi L 72 cm, H 25 cm, P 54 cm, art. KBB272. La struttura è in essenza Rovere thermo, profili in alluminio finitura bronzo e ante in vetro argentato bronzo.

*Composition made up of a custom made mirror, Corian top, L 216 cm, H 12,5 cm D 54 cm, art. CRS54 with integrated sinks model art. MYSL0T72. AYATI tap series in satin finish art. AY921SA and art. AY600SA. Three cabinets from the BESPOKE collection L 72 cm, H 25 cm, D 54 cm, art. KBB272. The structure is in Rovere thermo, frame in aluminum bronze finish and fronts in bronze mirrored glass.*





Nella foto, la composizione illustrata nella pagina precedente, nella variante con top in Corian art. CRS54 e lavabi integrati art. OPENSLOT72.

*In the picture from the previous page an alternative with Corian top art. CRS54 with integrated sinks art. OPENSLOT72.*









Su richiesta:

L'armadiatura comprende quattro colonne a due ante con struttura e cassetti interni in Rovere thermo, profili in alluminio finitura bronzo e ante in vetro trasparente bronzo. Le dimensioni delle quattro colonne sono L 108 cm, H 210 cm, P 47 cm.

*Upon request:*

*The wardrobe is made up of four double door high cabinets with carcass and internal drawers in Rovere thermo, frames in bronze aluminum and transparent bronze glass. The measurements of the four high cabinets are L 108 cm D 47 cm.*



La colonna art. KC3472, L 72 cm, H 150 cm, P 21,6 cm, è composta da due ante con struttura in Rovere thermo, profili in alluminio finitura bronzo e ante in vetro argentato bronzo. All'interno delle ante gli specchi art. KS3.

*The high cabinet art. KC3472, L 72 cm, H 150 cm, D 21,6 cm has two fronts and structure in Rovere thermo, frame in aluminum bronze finish and fronts in bronze mirrored glass. On request it is possible to insert a mirror on the inside of the doors art.KS3..*





Pensili con due ante e tre ripiani interni art. KE40108, la struttura è in Rovere thermo, il telaio in alluminio finitura bronzo mentre il frontale è in vetro argentato bronzo. Le dimensioni sono L 108 cm H 100 cm e P 21,6 cm.

*Double door wall cabinet with three internal shelves art. KE40108, the carcass is in Rovere thermo, the frame is in bronze aluminum while the front is in silvered bronze glass. The dimensions are L 108 cm H 100 cm and D 21,6 cm.*



Nella foto due specchiere affiancate art. BSK21090 con telaio in alluminio finitura bronzo, dimensioni L 90 cm, H 210 cm.

*In the picture two mirrors next to each other art. BSK21090 with aluminum bronze frame L 90 cm, H 210 cm.*







Su richiesta:

L'armadiatura comprende tre colonne a due ante con struttura in Noce canaletto, profili in alluminio finitura bronzo e ante in vetro trasparente fumé. Le dimensioni delle tre colonne sono L 90 cm, H 210 cm, P 40 cm.

*Upon request:*

*The wall system includes three high cabinets and two fronts with structure in Noce canaletto, frame in aluminum bronze finish and fronts in transparent fumé glass. The dimensions of the three cabinets are L 90 cm, H 210 cm, D 40 cm.*



Vetro trasparente bronzo

*Transparent bronze glass*





Composizione formata da cinque colonne di H 175 cm, la struttura è Skin cenere, i profili delle ante sono in alluminio finitura titanio e i frontali in vetro trasparente fumé. Le colonne sono di diversa larghezza, a partire da sinistra, L 45 cm art. KC1745, a sinistra e a destra del camino di L 72 cm con doppia anta art. KC3772, L 45 cm art. KC1745, L 36 cm art. KC1736. La vasca a semincasso in Cristalplant art. DUNE2 e il camino art. CANTOMC63, con bruciatore a bioetanolo art. LAFLACA, appartiene alla collezione CANTO DEL FUOCO.



*Composition made up of five high cabinets H 175 cm, the structure in Skin cenere, the frames are in aluminum titanium finish and fronts in transparent fumé glass. The high cabinets are of different widths, starting from the left, L 45 cm art. KC1745, two L 72 cm with double fronts art. KC3772, L 45 cm art. KC1745, L 36 cm art. KC1736. The bathtub in Cristalplant art. DUNE2 and fireplace art. CANTOMC63 is from the CANTO DEL FUOCO series, with bioethanol burner art. LAFLACA*



La composizione comprende un mobile sospeso con struttura Rovere thermo, profili in alluminio finitura bronzo, ante in vetro trasparente bronzo, formato da tre basi con due ante ciascuna, L 90 cm P 47 cm H 37,5 cm art. KIBM5490, il top art. IT21 è in essenza Rovere thermo. Su richiesta è possibile avere l'illuminazione interna. A fianco, camino art. TEKA144, versione sinistra.

*The composition has suspended furniture with carcass and top art. IT21 in Rovere thermo, frames in bronze aluminum, fronts in transparent bronze glass, made up of three double door cabinets, L 90 cm D 47 cm art. KIBM5490. Internal LED lighting available upon request. To the side, fireplace art. TEKA144 left hand version.*





I tre pensili con doppia anta, sono ciascuno di L 90 cm, P 33,6 cm e H 37,5 cm, speciali in profondità. La struttura è Rovere thermo, il profilo delle ante è in alluminio finitura bronzo, il vetro è trasparente bronzo.

*The three wall cabinets with double doors are L 90 cm, D 33,6 cm and H 37,5 cm custom in depth. Structure in Rovere thermo frame in aluminum bronze finish and bronze transparent glass. Internal LED lighting available upon request.*





Su richiesta è possibile avere l'illuminazione interna.

*Internal LED lighting available upon request.*



Vetro trasparente bronzo

*Transparent bronze glass*

## BESPOKE finiture vetri

Trasparente, acidato, argentato, cannettato e anche laccato: sono infinite le declinazioni del vetro, sono molteplici le nuove finiture che confermano la vocazione sartoriale di antoniolupi e la capacità di interpretare la materia in modo innovativo. Superfici capaci di trasformare l'immagine dei volumi, di dialogare in modo diverso con la luce, di esprimere personalità, carattere e stile, alcune esaltano il contenuto dei volumi, altre in parte lo celano ed altre ancora lo nascondono. I colori proposti sono numerosi e le soluzioni si moltiplicano grazie alla combinazione tra tonalità ed effetti particolari. Perché ogni composizione sia unica, ogni proposta sia cucita addosso ai desideri del cliente, ogni ambiente della casa possa diventare piena espressione di una "bellezza personalizzata".

## BESPOKE glass finishes

*Clear, acid, mirrored, ribbed and lacquered: there are infinite variations of glass, there are many new finishes that confirm the tailoring vocation of antoniolupi and the ability to interpret matter innovatively. Surfaces capable of transforming the image of volumes, dialogue differently with light, expressing personality, character, and style, some exalt the contents of the volumes, others partially conceal it and others hide it. The colors offered are numerous and the solutions are multiplied by the combination of shades and special effects. Because every composition is unique, each proposal is adapted to the customer's desires, any home environment can become a full expression of "personal beauty".*



Vetro trasparente fumé

*Transparent fumé glass*



Vetro trasparente fumé, vetro argentato fumé e vetro acidato fumé

*Fumé transparent glass, fumé mirrored glass and fumé acid glass*



Vetro acidato bronzo

*Bronze acid glass*



Vetro acidato fumé

*Fumé acid glass*



Vetro argentato naturale

*Natural mirrored glass*



Vetro argentato bronzo

*Bronze mirrored glass*



Vetro argentato fumé

*Fumé mirrored glass*



Vetro riflettente fumé

*Reflective fumé glass*



Vetro laccato acidato come da nostro campionario colori.

*Lacquered acid glass as per our colour samples.*





Vetro cannettato trasparente

*Ribbed clear glass*



Vetro cannettato laccato come da nostro campionario colori.

*Ribbed lacquered glass as per our coloursamples.*

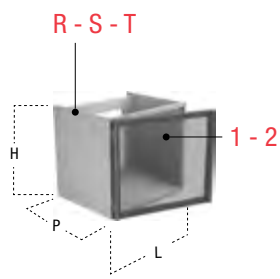
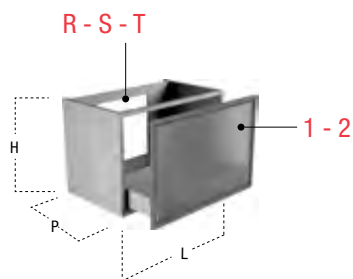

Ante e cassetti non possono essere abbinati in un'unica composizione. Il telaio in alluminio può essere in finitura bronzo, titanio, zirconio e champagne. Per calcolare il prezzo di un elemento è necessario scegliere la finitura della struttura identificata dalle lettere R, S, T e la finitura dei frontali identificati dai numeri 1 e 2.

Door fronts and drawer fronts cannot be combined in a single composition. All fronts can have the frames in bronze, titanium, zirconium, champagne finish. To calculate the price of an element it is necessary to select the finish of the structure identified by the letters R, S, T as well as the finish of the fronts identified by numbers 1 and 2.

FINITURE STRUTTURE - STRUCTURE FINISH



FINITURE TELAI - FRAME FINISH

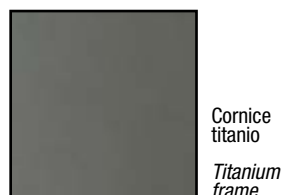
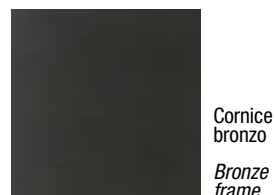

FINITURE FRONTALI ANTE E CASSETTI - DOOR AND DRAWER FRONT FINISH

1



Vetro trasparente bronzo  
*Transparent bronze glass*

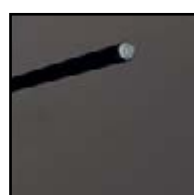

Vetro trasparente fumé  
*Transparent fumé glass*



Vetro argentato naturale  
*Natural silvered glass*



Vetro argentato bronzo  
*Natural silvered glass bronze*



Vetro argentato fumé  
*Natural silvered glass fumé*



Vetro cannettato trasparente  
*Ribbed clear glass*

2



Vetro laccato acidato come da nostro campionario colori  
*Lacquered acid glass as per our colour samples*



Vetro riflettente fumé  
*Reflective fumé glass*



Vetro acidato bronzo  
*Bronze acid glass*



Vetro acidato fumé  
*Fumé acid glass*

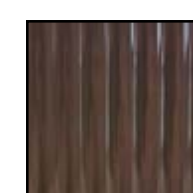

Vetro cannettato laccato come da nostro campionario colori  
*Ribbed lacquered glass as per our colour samples*



TOP IN MARMO - MARBLE TOP  
EMPERADOR

PORTA LAVABI CON CASSETTO / SINK UNITS WITH DRAWERS

Prof. 47/54

Porta lavabo con 1 cassetto sagomato internamente per sifone  
Sink unit with 1 drawer internally shaped for siphon

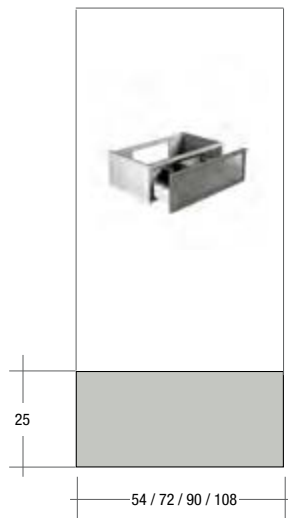

Porta lavabo con un cassetto  
Large drawer sink unit

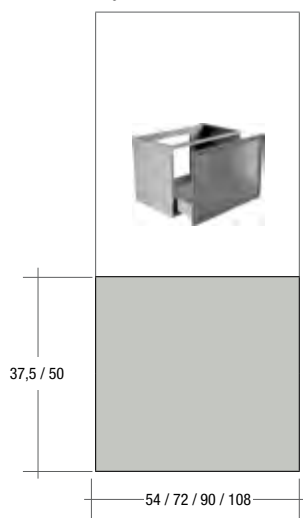

Porta lavabo con 2 cassetti di cui 1 sagomato internamente per sifone  
Sink unit with 2 drawers of which 1 internally shaped for siphon

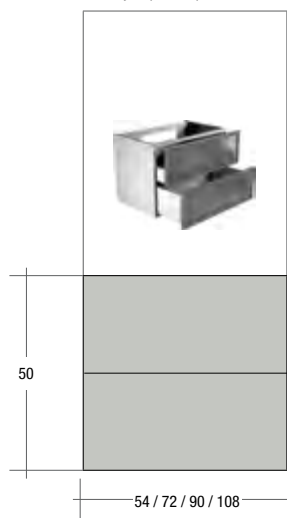

BASI CON CASSETTO / CABINET WITH DRAWERS

Prof. 47/54

Base con 1 cassetto  
Single drawer cabinet

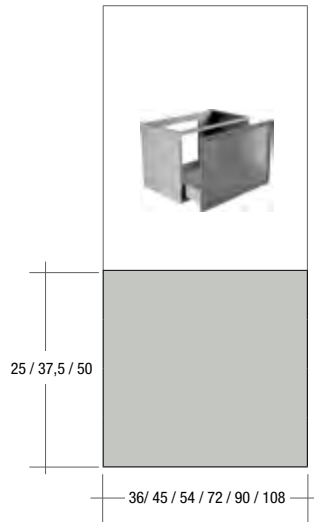

Base con 2 cassetti  
Cabinet with 2 drawers

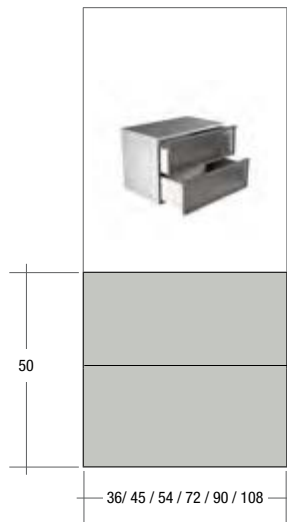

Prof. 43,4/54,4

Base con 2 cassetti  
Cabinet with 2 drawers

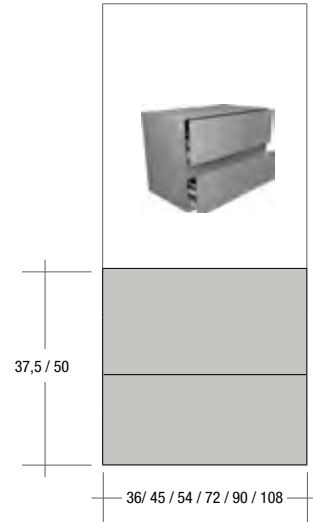

PORTA LAVABI CON ANTE / SINK UNITS WITH DOORS

Prof. 47/54

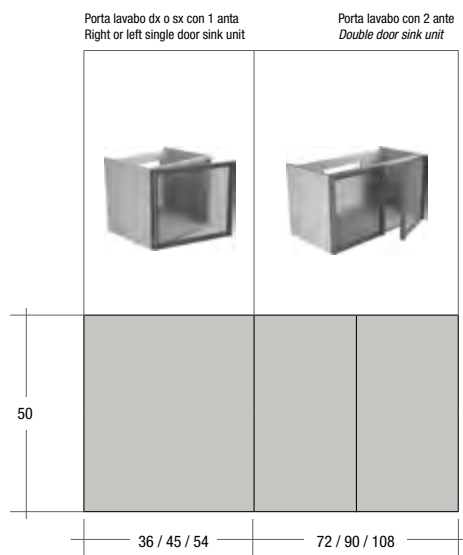
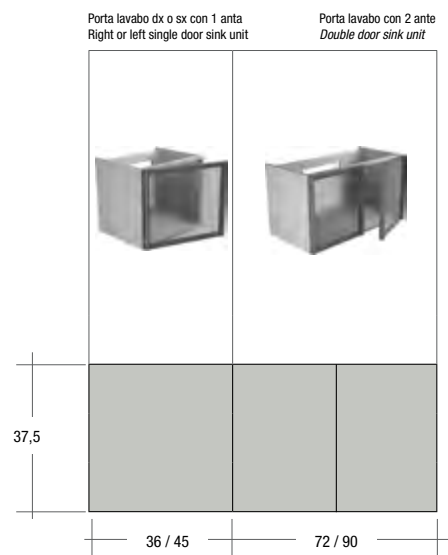

BASI CON ANTE / CABINET WITH DOORS

Prof. 47/54

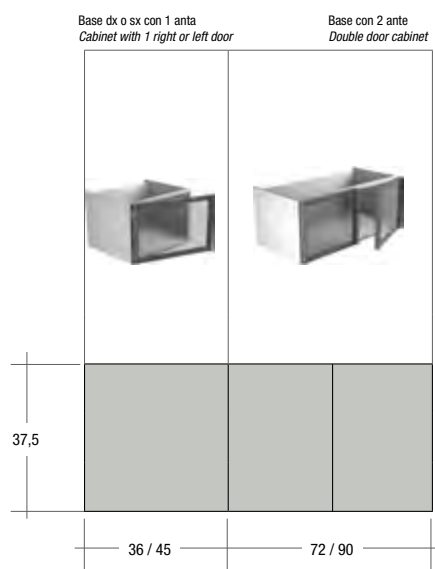

Prof. 47/54

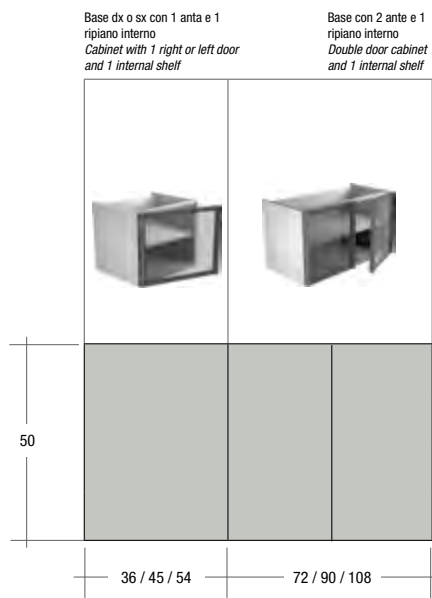

## PANTA REI design Carlo Colombo

Eccellenza che diventa esclusività, per un lusso contemporaneo fatto di linee pulite e forme essenziali, materiali naturali e dettagli preziosi che trasmettono armonia ed equilibrio all'insieme.

La qualità unica delle lavorazioni unita alla possibilità di scegliere dimensioni, colori e finiture fanno di Panta Rei una collezione sartoriale all'insegna dell'eccellenza. I mobili, disponibili in finitura laccata o in essenza e i lavabi della collezione, comunicano un universo di valori e principi fondanti nei quali la qualità diventa il filo conduttore del progetto, in grado di sollecitare un mondo di sensazioni intime e arcaiche, di riti che si ripetono nel tempo, di abitudini che si trasformano nel segno della continuità.

Un'identità forte, nella quale gli spessori dei contenitori, esteticamente importanti, sono alleggeriti e sollevati da terra dallo zoccolo smussato e dal particolare taglio a 45° dei profili, che oltre a snellire in maniera significativa anche le sezioni a forte spessore, contribuisce a migliorare la qualità estetica complessiva dell'insieme. La perfezione raggiunta con Panta Rei nella laccatura e nell'impiallacciatura ha segnato un punto di svolta per antoniolupi, ha definito uno standard d'eccellenza che è stato da quel momento trasmesso a tutta la produzione. Da quel momento in poi il livello qualitativo diventerà il parametro di riferimento per ogni prodotto, l'attenzione ai dettagli il tratto distintivo di un modo di operare e prima di tutto di pensare.

La preziosità del legno, il calore delle essenze più ricercate, l'uniformità perfetta dei laccati opachi, i riflessi dei lucidi: la materia diventa design con Panta Rei, la qualità di ogni singolo elemento viene messa a servizio dell'immagine complessiva, del dialogo con le forme dei lavabi, della capacità di interpretare lo spazio, della volontà di definire un ambiente bagno senza confini.

*Excellence that becomes exclusive for contemporary luxury made of clean lines and basic shapes, natural materials and precious details that convey harmony and balance.*

*The unique quality of workmanship coupled with the ability to choose sizes, colors and finishes make Panta Rei a tailored collection characterized by excellence. The furniture, available in a lacquered or wood finish communicate with the washbasins of the collection.*

*A strong identity, in which the thicknesses of the cabinets, aesthetically important, are lightened and raised from the ground by the beveled socket and details cut at 45°. The lacquering and veneering achieved with the Panta Rei collection clearly marked a turning point for the company setting a standard of excellence transmitted to the rest of the production. From that moment on, the quality will become the benchmark for each product, the attention to detail; the hallmark of a way of working and thinking.*

*The preciousness of the woods, warmth from the most sought after materials, the perfect uniformity of the matt lacquers and the reflections of the glossy colours: matter becomes design with Panta Rei. The quality of each element is put in the service of the overall image, dialogue with the shapes of the washbasins, the ability to interpret the space, the desire to define a bath environment without borders.*







Cassetto interno opzionale art. SLIM54 e attrezzature STRATO con divisori in vetro fumè.

*Internal optional drawer art. SLIM54 and accessories STRATO with dividers in fumè glass.*





PANTA REI

Attrezzature STRATO con divisori in vetro fumè e vaschetta porta oggetti.

Accessories STRATO with dividers in fumè glass and storage compartment.

I pensili L 72 cm, H 25 cm, P 14 cm ciascuno, sono in vetro extrachiaro con schienale laccato Bianco opaco, art. ICE6; lo specchio art. FILA75W di L 216 cm e H 75 cm, la rubinetteria AYATI è in acciaio lucido, art. AY921LU e art. AY600LU. Il mobile sul quale sono appoggiati due lavabi in marmo di Carrara art. PIXEL45, è composto da tre moduli, due di L 144 cm art. PI4144 e uno di L 180 cm art. PI4180, tutti di H 37,5 cm e P 54 cm, di colore Cemento lucido.

*The wall cabinets L 72 cm, H 25 cm, D 14 cm each and are in extraclear glass with lacquered back panel in matt Bianco art. ICE6; the mirror art. FILA75W L 216 cm and H 75 cm, the AYATI taps are in polished steel art. AY921LU and art. AY600LU.*

*The furniture with two Carrara marble sinks art. PIXEL45 is made up of three cabinets, two L 144 cm art. PI4144 and one L 180 cm art. PI4180, all are H 37,5 cm and D 54 cm lacquered glossy Cemento.*









PANTA REI

Lo specchio è un art. VARIO50W, L 180 cm, H 50 cm con due coppie di lampade art. BOLLA2, la composizione sottostante di L 180 cm, P 54 cm, H 37,5 cm è formata dal mobile in Rovere thermo art. PI14180 e dal top in Quarzomood colore Terra con buca integrata, art. NIDOQ272. Il rubinetto AYATI è un art. AY301LU.

*The mirror is art. VARIO50W, L 180 cm, H 50 cm with a pair of lamps art. BOLLA2, the composition below is L 180 cm, D 54 cm, H 37,5 cm is made up of cabinet art. PI14180 in Rovere thermo and top in Quarzomood colour Terra with integrated basin art. NIDOQ272. The AYATI tap is art. AY301LU.*





La composizione è arricchita dall'inserimento del pianetto copripiletta art. PIANETTOQ1, dai cassetti interni opzionali art. SLIM54 e dall'attrezzatura STRATO in vetro fumé.

*The composition is completed with the drain cover art. PIANETTOQ1 and the internal optional drawers art. SLIM54 with STRATO drawer dividers in smoked glass.*







Lo specchio a sinistra è un art. COLLAGE222, quello a destra è l'art. COLLAGE221, entrambi L 36 cm e H 108 cm, la composizione sottostante è l'art. PI22180 di L 180 cm, P 54 cm, H 37,5 cm in finitura Rovere thermo, più il top in Flumood art. BC254, in finitura Satin, con due buche integrate art. NIDO e pianetto opzionale art. PIANETTO2. I rubinetti sono della serie AYATI art. AY301SA in acciaio satinato.

*The mirror to the left is art. COLLAGE222, the one on the right is art. COLLAGE221, both L 36 cm and H 108 cm. The composition below is art. PI22180 measuring L 180 cm, D 54 cm H 37,5 cm in Rovere thermo with a top in Flumood art. BC254 Satin finish with two Integrated sinks art. NIDO and optional surface art. PIANETTO2. The tap series AYATI art. AY301SA in satin stainless steel.*



La composizione comprende due specchi L 50 cm, H 108 cm con cornice color Matita opaco art. SFOGLIA50, rubinetteria AYATI in finitura satinata art. AY921SA e art. AY600SA, due moduli di L 180 cm, H 37,5 cm, P 54 cm, in essenza Rovere matita, art. PI12180 a destra e art. PI14180 a sinistra; i lavabi da appoggio in Cristalplant, sono l'art. SOLIDEA.

*The composition includes two mirrors L 50 cm H 108 cm with frame lacquered matt Matita art. SFOGLIA50, AYATI taps in the satin finish art. AY921SA and art. AY600SA, two cabinets L 180 cm, H 37,5 cm, P 54 cm in essence Rovere matita art. PI12180 on the right and art. PI14180 on the left; the top mount sinks are in Cristalplant, art. SOLIDEA.*







La composizione comprende uno specchio art. FLASH100W, rubinetteria AYATI in finitura lucida, art. AY921LU e art. AY600LU. Il mobile è composto da due moduli, ognuno di L 144 cm, H 37,5 cm, P 54 cm, art. PI4144 laccati Ovatta lucido. Lavabi da appoggio in Ceramilux art. SERVORETTO50. Di lato alla composizione, il camino CANTO DEL FUOCO art. CANTOMC63 con bruciatore art. LAFLACA.

*The composition includes a mirror art. FLASH100W, AYATI taps in a polished finish art. AY921LU and art. AY600LU. The furniture is made up of two cabinets each L 144 cm, H 37,5 cm, D 54 cm, art. PI4144 lacquered glossy Ovatta. Ceramilux top mount sinks art. SERVORETTO50.*

*Next to the composition is a fireplace CANTO DEL FUOCO art. CANTOMC63 and burner art. LAFLACA.*



Specchio art. NEUTROLED50W di L 180 cm, H 50 cm, rubinetteria AYATI art. AY921LU e art. AY600LU, lavabo da appoggio in Ceramilux art. BOLO45. Il mobile PANTA REI DOBLE è composto da due basi art. PI5645 di L 45 cm e da un portalavabo art. PI5490 L 90 cm, tutti H 37,5 cm e P 54 cm, colore Terracotta lucido.

*Mirror art. NEUTROLED50W measuring L 180 cm, H 50 cm, AYATI taps art. AY921LU and art. AY600LU, top mount Ceramilux sink art. BOLO45. The furniture PANTA REI DOBLE is made up of two cabinets art. PI5645 L 45 cm and one sink unit art. PI5490 L 90 cm all H 37,5 cm and D 54 cm, lacquered glossy Terracotta.*



Specchio art. NEUTROLED50W di L 216 cm, H 50 cm, rubinetteria AYATI art. AY921LU e art. AY600LU, e lavabo da appoggio in Ceramilux art. BOLO45. Il mobile PANTA REI DOBLE è composto da due basi art. PI5672 di L 72 cm e da un portalavabo art. PI5472 L 72 cm, H 37,5 cm e P 54 cm, colore Terracotta lucido.

*Mirror art. NEUTROLED50W measuring L 216 cm, H 50 cm, AYATI taps art. AY921LU and art. AY600LU, top mount Ceramilux sink art. BOLO45. The furniture PANTA REI DOBLE is made up of two cabinets art. PI5672 L 72 cm and a sink unit art. PI5472 L 72 cm, H 37,5 cm and D 54 cm, lacquered glossy Terracotta.*



Attrezzature STRATO con divisori in vetro fumè.

Accessories STRATO with dividers in fumè glass.





PANTA REI





La composizione nella foto comprende uno specchio L 108 cm, art. VARIO75W, con interruttore art. MAGIC. Il mobile laccato Strada lucido è composto da due basi L 72 cm art. PI5672 e da un porta lavabo L 72 cm art. PI5472, H 37,5 e P 54 cm. I tre pensili della collezione BESPOKE, art. KE1736 di L 36 cm, H 75 cm, P 21,6 cm, hanno la struttura color Strada lucido, con i profili in alluminio finitura titanio e l'anta in vetro argentato fumé. Il lavabo in Flumood è l'art. AG03.

*The composition in the photo includes a mirror L 108 cm art. VARIO75W with switch art. MAGIC. The cabinet is lacquered glossy Strada and made up of two cabinets L 72 cm art. PI5672 and one sink unit L 72 cm art. PI5472, H 37,5 cm and D 54 cm. The three wall cabinets of the BESPOKE collection art. KE1736 L 36 cm, H 75 cm, D 21,6 cm are lacquered glossy Strada with profile in titanium and doors in silvered glass fumé. The sink in Flumood is art. AG03.*





La composizione comprende uno specchio art. FLASH75W, L 180 cm, H 75 cm, il mobile art. PI4180, L 180 cm, P 54 cm, H 37,5 cm e il top in Corian L 180 cm, art. CR254, con lavabo integrato art. MYSLOT90. La rubinetteria è BIKAPPA in finitura lucida art. BK200N.

*The composition includes mirror art. FLASH75W, L 180 cm, H 75 cm. The cabinet art. PI4180, L 180 cm, D 54 cm, H 37,5 cm and the top in Corian L 180 cm, art. CR254 with integrated sink art. MYSLOT90. Polished BIKAPPA tap art. BK200N.*







La composizione comprende uno specchio realizzato su misura con inserita rubinetteria AYATI art. AY921SA e art. AY600SA, un top in Corian art. CRS54 con due lavabi integrati art. MYSL0T72 e due sifoni art. MICRO in acciaio inox satinato.

Il mobile art. PB10216 di L 216 cm, H 25 cm e P 54 cm è colore Melograno lucido e si completa con l'attrezzatura interna STRATO con divisori in vetro fumé.

*The composition has a custom made mirror with AYATI taps art. AY921SA and art. AY600SA, a Corian top art. CRS54 with two integrated sink models MYSL0T72 and two siphons art. MICRO in satin stainless steel.*

*The cabinet art. PB10216 L 216 cm H 25 cm and D 54 cm is lacquered glossy Melograno and has internal drawer accessories STRATO with dividers in fumé glass.*







Composizione con uno specchio L 216 cm, H 75 cm, art. FLASH75W, un mobile L 216 cm, P 54 cm, H 25 cm, in essenza Rovere castano art. PB4216. Top in Corian art. CRS15, con due lavabi integrati art. SLOT. La rubinetteria BIKAPPA è in finitura lucida art. BK200N.

*Composition with a mirror L 216 cm, H 75 cm, art. FLASH75W, a cabinet L 216 cm, D 54 cm, H 25 cm in Rovere castano art. PB4216. Top in Corian art. CRS15 with two integrated sinks art. SLOT. Polished BIKAPPA tap art. BK200N.*





La composizione comprende uno specchio art. FLASH75W, L 180 cm, H 75 cm, un top in Corian L 180 cm, H 12,5 cm, P 54 cm art. CRS54, con lavabo integrato art. MYSLOT72. Il mobile, L 180 cm, P 54 cm, H 25 cm, art. PB4180, è in essenza Rovere grigio. La rubinetteria è BIKAPPA in finitura lucida art. BK200N.

*The composition includes mirror art. FLASH75W, L 180 cm, H 75 cm, top in Corian L 180 cm, H 12,5 cm, D 54 cm art. CRS54 with integrated sink art. MYSLOT72. The cabinet L 180 cm, D 54 cm, H 25 cm, art. PB4180 Rovere grigio. Polished BIKAPPA tap art. BK200N.*







La composizione comprende uno specchio art. NEUTROLED90W e uno art. NTKIT50W, rubinetteria AYATI, art. AY301LU da piano e art. AY921LU art. AY600LU, da parete. Top in Flumood finitura Satin, art. BCS54, con lavabi sopra piano art. SIMPLOTONDO e art. SIMPLO42. Il mobile L 216 cm, H 37,5 cm, P 47 cm, è laccato colore Cipria lucido. art. PIM10216.

*The composition includes a mirror art. NEUTROLED90W and one mirror art. NTKIT50W, AYATI taps art. AY301LU on the top and art. AY921LU and art. AY600LU, wall mounted. Top in Flumood Satin finish art. BCS54 with top mount sinks art. SIMPLOTONDO and art. SIMPLO42. The cabinet L 216 cm H 37,5 cm D 47 cm is lacquered glossy color Cipria art. PIM10216.*



La composizione comprende due specchi L 50 cm, H 108 cm, con cornice laccata Grigio Piombo opaco, art. SFOGLIA50, rubinetteria AYATI in finitura satinata, art. AY921SA e art. AY600SA, un top in Flumood Satin art. BCS54, con doppio lavabo integrato art. NIDO, sifone art. MICRO in acciaio inox satinato. Il mobile L 216 cm, H 25 cm, P 54 cm, è laccato Matita opaco, art. PB10216. Il porta salviette art. RETTA4108, è L 108 cm, verniciato Matita goffrato, a lato il porta dispenser doppio, da incasso a parete, in acciaio AISI 304 finitura alluminio art. SESAM03.

*The composition has two mirrors L 50 cm, H 108 cm with frame lacquered matt Grigio Piombo art. SFOGLIA50, satin AYATI taps art. AY921SA and art. AY600SA, a top in Satin Flumood art. BCS54 with double integrated sink art. NIDO, satin stainless steel siphon art. MICRO. The cabinet L 216 cm, H 25 cm, D 54 cm is lacquered matt matita art. PB10216. The towel rail art. RETTA4108, is L 108 cm, lacquered embossed Matita and next to it art. SESAM03 double encased dispenser in steel AISI 304 aluminum finish.*









La composizione comprende due specchi art. FLASH100W e due top in essenza Noce canaletto L 144 cm, H 12,5 cm art. BANCO154, due lavabi da appoggio in Flumood art. URNAMOOD. La rubinetteria è AYATI in finitura satinata art. AY921SA e art. AY600SA, come il sifone art. MICRO. Il mobile PANTA REI CENTRO laccato Strada opaco L 72 cm, H 50 cm, P 54 cm, art. PA2672. Le colonne in vetro extrachiaro, con schienale laccato Matita opaco L 27 cm, H 150 cm, P 14 cm, sono l'art. ICE3.

*The composition has two mirrors art. FLASH100W and two tops in Noce canaletto L 144 cm, H 12,5 cm art. BANCO154, two sinks in Flumood art. URNAMOOD. The AYATI tap in the satin finish art. AY921SA and art. AY600SA as is the siphon art. MICRO. The cabinet PANTA REI CENTRO lacquered matt Strada L 72 cm, H 50 cm, D 54 cm, art. PA2672. The high cabinets in extra clear glass with back lacquered in matt Matita L 27 cm, H 150 cm, D 14 cm, are art. ICE3.*





PANTA REI

La composizione comprende due moduli art. PB10216, L 216 cm, H 25 cm, P 54 cm, laccati Ovatta goffrato, due specchi L 144 cm, H 100 cm, art. FLASH100W, al centro, il pensile L 27 cm, H 100 cm, P 14 cm, in vetro extrachiario con schienale laccato Bianco opaco art. ICE1. Top in Flumood finitura Satin L 216 cm, H 12,5 cm, P 54 cm, art. BCS54. Lavabo in Ceramilux lucido, art. GEST063, con rubinetteria AYATI in finitura lucida art. AY301LU.

*The composition includes two cabinets art. PB10216, L 216 cm, H 25 cm, D 54 cm lacquered embossed Ovatta, two mirrors L 144 cm, H 100 cm, art. FLASH100W, in the center the wall cabinet L 27 cm, H 100 cm, D 14 cm in extra clear glass with back panel lacquered matt Bianco art. ICE1. Top is in Flumood Satin finish L 216 cm, H 12,5 cm, D 54 cm art. BCS54. Sink in glossy Ceramilux art. GEST063, AYATI taps in polished finish art. AY301LU.*





Pensile con anta a specchio L 162 cm, H 50 cm, P 32 cm, art. SEGRETO, laccato Mostarda opaco; top in Flumood finitura Satin L 216 cm, H 12,5 cm, P 54 cm, art. BCS54, con lavabo in Ceramilux lucido art. SERVORETTO63 e rubinetteria AYATI in finitura lucida art. AY200LU. Il mobile L 216 cm, H 25 cm, P 54 cm, laccato Ovatta opaco è l'art. PB10216.

*Wall cabinet with mirrored front L 162 cm, H 50 cm, D 32 cm, art. SEGRETO, lacquered matt Mostarda; top In Flumood Satin finish L 216 cm, H 12,5 cm, D 54 cm, art. BCS54 with glossy Ceramilux sink art. SERVORETTO63 and AYATI tap in the polished finish art. AY200LU. The furniture L 216 cm, H 25 cm, D 54 cm, is lacquered matt Ovatta art. PB10216.*



Due composizioni uguali, ognuna composta da un pensile con anta a specchio L 162 cm, H 50 cm, P 32 cm, art. SEGRETO, laccato Mostarda opaco, top in Flumood finitura Satin L 216 cm, H 12,5 cm, P 54 cm, art. BCS54 e lavabo in Cristalplant art. SOLIDEA, con rubinetteria AYATI in finitura lucida, art. AY200LU. I due mobili sono laccati Meringa opaco art. PB10216.

*Two identical cabinets each made up of a wall cabinet with mirrored front L 162 cm, H 50 cm, D 32 cm, art. SEGRETO lacquered matt Mostarda, top in Flumood Satin finish L 216 cm, H 12,5 cm, D 54 cm, art. BCS54 and sink in Cristalplant art. SOLIDEA, polished AYATI tap art. AY200LU. The two cabinets are lacquered matt Meringa art. PB10216.*









Il mobile, L 216 cm, H 37,5 cm, P 54 cm art. PI10216 è laccato Mostarda opaco e corredato di zoccolo H 5 cm, laccato Nero goffrato art. PZ54. A sinistra: lavabo in Cristalplant art. BARREL3, con rubinetteria AYATI in finitura satinata art. AY902SA.

*The furniture L 216 cm, H 37,5 cm, D 54 cm, art. PI10216 is lacquered matt Mostarda, has an embossed lacquered Nero plinth H 5 cm art. PZ54. On the left: sink in Cristalplant art. BARREL3 with AYATI tap in satin finish art. AY902SA.*





A sinistra, la composizione comprende uno specchio L 36 cm, H 108 cm, art. SPI04W, un mobile in Rovere matita L 180 cm, H 37,5 cm, P 54 cm, art. PI4180. Lavabo in Ceramilux lucido, art. FOGLIO63 e rubinetteria BIKAPPA in finitura lucida art. BK200N. Sopra, soluzione con rubinetteria AYATI in finitura satinata art. AY200SA.

*On the left, the composition includes a mirror L 36 cm, H 108 cm, art. SPI04W, a cabinet in Rovere matita L 180 cm, H 37,5 cm, D 54 cm, art. PI4180. Glossy Ceramilux sink art. FOGLIO63 and BIKAPPA taps in polished chrome finish art. BK200N. Above solution with the AYATI tap in satin art. AY200SA.*



Composizione formata da quattro colonne L 45 cm, H 150 cm, P 22 cm, laccate Cemento opaco art. PC1045. Il mobile L 216 cm, P 54 cm, H 50 cm, art. PA10216, è laccato Grigio Smog opaco. Sul mobile, due lavabi sopra piano ad incasso in Ceramilux lucido, art. FOGLIO63. Rubinetteria della serie BIKAPPA, con finitura lucida art. BK200N. Lo specchio è l'art. FLASH75W, L 144 cm, H 75 cm. Di lato alla composizione, il camino bifacciale CANTO DEL FUOCO, L 108 cm, art. CANTOBC108 e due bruciatori art. LAFLACA.

*Composition includes four high cabinets L 45 cm, H 150 cm, D 22 cm, lacquered matt Cemento art. PC1045. The cabinet L 216 cm, D 54 cm, H 50 cm, art. PA10216 is lacquered matt Grigio Smog. On the cabinet are two sinks in glossy Ceramilux art. FOGLIO63. Polished finish BIKAPPA taps art. BK200N. The mirror art. FLASH75W, L 144 cm, H 75 cm. To the side is the double faced fireplace CANTO DEL FUOCO, L 108 cm, art. CANTOBC108 and two burners art. LAFLACA.*



PANTA REI







La composizione comprende un mobile art. PA10216, L 216 cm, P 54 cm, H 50 cm, laccato Grigio Vesuvio opaco, sopra i due lavabi in Pietra Vesuvio art. PILA11. La rubinetteria è BIKAPPA in finitura lucida art. BK200N. Gli specchi sono L 36 cm, H 108 cm, art. SPIO4W.

*The composition includes a cabinet art. PA10216, L 216 cm, D 54 cm, H 50 cm lacquered matt Grigio Vesuvio with two sinks art. PILA11 in Pietra Vesuvio. Polished BIKAPPA tap art. BK200N. Mirrors L 36 cm, H 108 cm, art. SPIO4W.*





La composizione comprende, uno specchio L 180 cm, H 75 cm art. SPI0275W, un mobile L 180 cm, P 54 cm, H 50 cm, laccato color Bianco opaco art. PA4180, sopra il top in vetro color Matita acidato spessore 12 mm art. PT2; i lavabi sottopiano sono in Ceramilux lucido art. PIPER1 con rubinetteria BIKAPPA in finitura lucida art. BK200N. le colonne, sono laccate color bianco opaco, L 45 cm, H 150 cm, P 14 cm art. PC345.

*The composition includes a mirror L 180 cm, H 75 cm art. SPI0275W, a cabinet L 180 cm, D 54 cm, H 50 cm lacquered matt Bianco art. PA4180; acid glass top 12 mm thick art. PT2 color Matita and undermount sinks in glossy Ceramilux art. PIPER1. Polished BIKAPPA tap art. BK200N.*









La composizione in alto comprende uno specchio art. NEUTROLED75W di L 216 cm, H 75 cm, la rubinetteria AYATI in finitura satinata art. AY200SA e due lavabi da appoggio in Flumood art. CATINO. Il mobile PANTA REI CENTRO art. PA32216 è di L216 cm, H 50 cm e P 54 cm, laccato Cemento lucido.

*The composition above has a mirror art. NEUTROLED75W L 216 cm, H 75 cm, the AYATI tap in satin finish art. AY200SA and two top mount sinks in Flumood art. CATINO. The cabinet PANTA REI CENTRO art. PA32216 is L 216 cm, H 50 cm and D 54 cm lacquered glossy Cemento.*



La composizione comprende due specchi art. SPI04W di L 36 cm, H 108 cm, rubinetteria AYATI in finitura satinata, art. AY921SA e art. AY600SA. I due lavabi in Cristalplant sopraiano art. SOLIDEA, poggiano sul mobile PANTA REI CENTRO, L 216 cm, H 50 cm, P 54 cm, art. PA40216, in Rovere matita. I pensili in vetro extrachiario art. ICE6, L 72 cm, P 14 cm, hanno lo schienale laccato Ovatta opaco.

*The composition includes two mirrors art. SPI04W L 36 cm, H 108 cm, AYATI taps in the satin finish art. AY921SA and art. AY600SA. Two top mount sinks in Cristalplant art. SOLIDEA on the cabinet PANTA REI CENTRO, L 216 cm, H 50 cm, D 54 cm, art. PA40216 is Rovere matita. The wall cabinets in extra clear glass art. ICE6, L 72 cm, P 14 cm have a lacquered back in matt Ovatta.*









La composizione in alto comprende un pensile con anta a specchio art. SEGRETO, la rubinetteria AYATI è in finitura lucida, art. AY302LU, il top in Corian art. CR254 con lavabo integrato è l'art. SEGNO90 e il mobile PANTA REI CENTRO, L 180 cm, H 50 cm, P 54 cm, art. PA36180 è laccato Ovatta goffrato. Gli accessori sono della collezione PLAY.

*The composition on top includes a wall cabinet with mirrored door art. SEGRETO, AYATI tap in the polished finish art. AY302LU, Corian top art. CR254 with integrated sink art. SEGNO90 and the cabinet PANTA REI CENTRO, L 180 cm, H 50 cm, D 54 cm, art. PA36180 lacquered embossed Ovatta. Accessories from the PLAY series.*



La composizione PANTA REI CENTRO comprende un mobile in essenza Rovere naturale di L 216 cm, H 50 cm, P 54 cm, art. PA38216. Lavabo in Ceramilux lucido, art. SERVORETTO63 e rubinetteria BIKAPPA in finitura lucida art. BK904N.

*The composition PANTA REI CENTRO includes a cabinet in oak Rovere naturale L 216 cm, H 37,5 cm, D 54 cm, art. PA38216. Glossy Ceramilux sink art. SERVORETTO63 and BIKAPPA taps in polished finish art. BK904N.*



PANTIA REI





La composizione è formata da due mobili PANTA REI XL laccato Strada gofrato, ciascuno composto da un porta lavabo art. PI4672 e una base art. PI4872, ogni elemento è L 72 cm H 37,5 cm e P 54 cm. I due specchi art. SFOGLIA250 hanno la cornice laccata Strada gofrato. I lavabi sono in Flumood art. AG03.

*The composition is made up of two PANTA REI XL cabinets embossed lacquered Strada, each with one sink unit art. PI4672 and one cabinet art. PI4872, each element is L 72 cm H 37,5 cm and D 54 cm. The two mirrors art. SFOGLIA250 have the frame embossed lacquered Strada. The sinks are in Flumood art. AG03.*



La composizione sulla parete in colore Pomice goffrato è formata da cinque colonne art. PC1145, ciascuna di L 45 cm, H 175 cm, P 22 cm. La vasca in Cristalplant è una art. AGO4, la rubinetteria della serie AYATI in acciaio satinato è un art. AY903SA

*The composition on the wall is embossed lacquered Pomice and made up of five high cabinets art. PC1145, each is L 45 cm, H 175 cm, D 22 cm. The bathtub in Cristalplant is art. AGO4 the AYATI tap series in satin stainless steel art. AY903SA.*





PANTAFELI



La composizione comprende, sei pensili L 72 cm e L 27 cm, H 25 cm, P 14 cm, in vetro extrachiaro con schienale laccato Matita e Grigio Fango opaco. Il mobile PANTA REI XL è composto da due basi L 72 cm, art. PA4872 e da un porta lavabo L 72 cm, art. PA4672, la composizione è P 54 cm e H 50 cm, in essenza Noce canaletto. Il top è in Corian, L 216 cm, P 54 cm, art. CR254 con lavabo integrato art. SEGN072, la rubinetteria è AYATI in finitura satinata art. AY301SA. Lo specchio è L 72 cm, H 90 cm, art. FLASH90W.

*The composition includes six wall cabinets L 72 cm and L 27 cm, H 25 cm, D 14 cm in extra clear glass with lacquered back, colors matt Matita and Grigio Fango. The cabinet PANTA REI XL is composed of two elements L 72 cm, art. PA4872 and a sink unit L 72 CM, art. PA4672. The composition is D 54 cm and H 50 cm in Noce canaletto. Corian top L 216 cm, D 54 cm, art. CR254 with integrated sink art. SEGN072; satin AYATI tap art. AY301SA. Mirror L 72 cm, H 90 cm, art. FLASH90W.*



PANTIA REI



La composizione laccata Matita opaco, comprende due pensili con anta a specchio, completi di illuminazione, L 54 cm, H 50,5 cm, P 14,7 cm art. MANTRA150. I due mobili PANTA REI XL sono formati da due basi di L 72 cm art. PA4772 e due porta lavabi L 54 cm, P 40 cm e H 50 cm art. PA4554. I lavabi sono in Ceramilux lucido, art. GESTO54 e la rubinetteria è AYATI in finitura lucida art. AY301LU.



*The lacquered composition matt Matita includes two wall cabinets with mirrored door, complete with lighting, L 54 cm, H 50,5 cm, D 14,7 cm art. MANTRA150. The PANTA REI XL furniture are made up of two cabinets L 72 cm art. PA4772 and two sink units L 54 cm, D 40 cm and H 50 cm art. PA4554. Sinks in glossy Ceramilux art. GEST054 and polished AYATI tap art. AY301LU.*

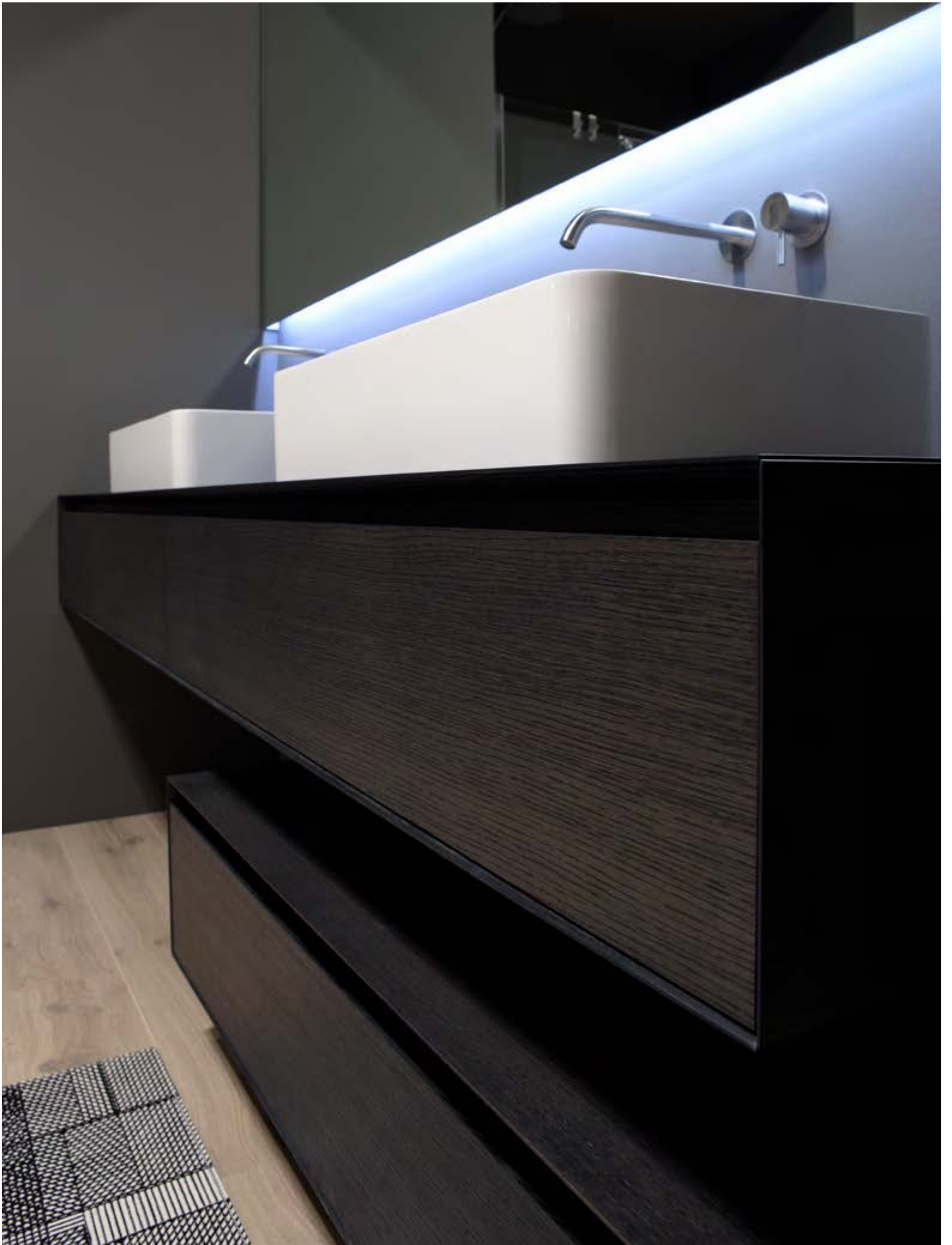



La composizione in essenza Rovere grigio, comprende due moduli di L 216 cm, P 54 cm, H 25 cm, art. PB4216 e art. PB20216, due lavabi in Ceramilux lucido art. SERVORETTO63, rubinetteria AYATI, finitura satinata, art. AY921SA e art. AY600SA. Lo specchio L 216 cm, H 75 cm, è l'art. FLASH75W. I pensili art. PE136, L 36 cm, H 75 cm, sono laccati Cemento opaco; i sanitari in ceramica satinata sono l'art. KOMODO3 e l'art. KOMODO4. Completano la composizione, gli accessori della collezione TAPE, in acciaio inox satinato AISI 304, come la placca di comando art. ONDA.

*The composition in Rovere grigio includes two cabinets L 216 cm, D 54 cm, H 25 cm, art. PB4216 and art. PB20216, two glossy Ceramilux sinks art. SERVORETTO63, AYATI taps in a satin finish art. AY921SA and art. AY600SA. The mirror L 216 cm, H 75 cm, is art. FLASH75W. Wall cabinets art. PE136, L 36 cm, H 75 cm, are lacquered matt Cemento; the sanitary ware in satin ceramic art. KOMODO3 and art. KOMODO4. To complete the composition are the TAPE accessories in satin stainless steel AISI 304 as is the plate art. ONDA.*







La composizione comprende due moduli laccati Bianco opaco di L 216 cm, P 54 cm; uno di H 37,5 cm art. PI10216 con zoccolo laccato Nero goffrato art. PZ54 e uno di H 25 cm art. PB10216, due lavabi in Flumood art. URNAMOOD, con rubinetteria AYATI in finitura satinata art. AY200SA. Lo specchio art. FLASH75W, è L 216 cm, H 75 cm.

*The composition includes two cabinets lacquered matt Bianco L 216 cm, D 54 cm; one is H 37,5 cm art. PI10216 and embossed lacquered Nero plinth art. PZ54 and the other H 25 cm art. PB10216, two sinks in Flumood art. URNAMOOD, satin AYATI tap art. AY200SA. The mirror art. FLASH75W, is L 216 cm, H 75 cm.*



La composizione comprende uno specchio su misura, un mobile L 180 cm, P 54 cm, H 25 cm, laccato Bianco opaco, art. PB4180. Lavabo in Flumood art. URNAMOOD. La rubinetteria è BIKAPPA in finitura lucida art. BK905.

*The composition includes a special size mirror, cabinet L 180 cm, D 54 cm, H 25 cm lacquered matt Bianco art. PB4180. sinks in Flumood art. URNAMOOD. Polished BIKAPPA tap art. BK905.*





Composizione con un mobile L 216 cm, P 54 cm, H 37,5 cm, in essenza Noce biondo art. PI4216, con zoccolo laccato nero gofrato, art. PZ54, ed un mobile laccato Bianco opaco art. PB4216. Lavabo in Flumood art. URNAMOOD. La rubinetteria è BIKAPPA in finitura lucida art. BK905N. Lo specchio art. FLASH50W è L 216 cm, H 50 cm.

*The composition with cabinet L 216 cm, D 54 cm, H 37,5 cm in Noce biondo art. PI4216, Nero embossed lacquered plinth art. PZ54 and a lacquered cabinet matt Bianco art. PB4216. Sink in Flumood art. URNAMOOD. Polished BIKAPPA tap art. BK905N. The mirror art. FLASH50W L 216 cm, H 50 cm.*







La composizione comprende tre mobili, due in essenza Noce biondo L 162 cm, P 54 cm, H 25 cm, art. PB24162 e uno laccato Bianco opaco di L 216 cm, H 25 cm, P 54 cm, art. PB4216. I lavabi sono in Pietra Luna art. PILA11, con rubinetteria BIKAPPA finitura lucida art. BK200N. Lo specchio L 162 cm, H 75 cm, art. FLASH75W.

*The composition includes three cabinets, two in Noce biondo L 162 cm, D 54 cm, H 25 cm, art. PB24162 and one lacquered matt Bianco L 216 cm, H 25 cm, D 54 cm, art. PB4216. The sinks in Pietra Luna art. PILA11 with BIKAPPA polished finish tap art. BK200N. The mirror L 162 cm, H 75 cm, art. FLASH75W.*



La composizione comprende tre mobili, due in essenza Rovere grigio L 180 cm, P 54 cm, H 25 cm, art. PB4180 e uno laccato Bianco opaco di L 180 cm, H 25 cm, P 54 cm, art. PB4180. Il lavabo è in Flumood art. URNAMOOD e la rubinetteria è BIKAPPA finitura lucida art. BK200N. Lo specchio, L 180 cm H 75 cm art. FLASH75W.

*The composition includes three cabinets, two in Rovere grigio L 180 cm, D 54 cm, H 25 cm, art. PB4180 and one lacquered matt Bianco L 180 cm, H 25 cm, D 54 cm, art. PB4180. Sink in Flumood art. URNAMOOD and BIKAPPA polished finish tap art. BK200N. The mirror L 180 cm H 75 cm art. FLASH75W.*





PANTARREI





La composizione comprende tre mobili, un porta lavabo L 72 cm, P 54 cm, H 50 cm, in essenza Rovere sbiancato art. PA272, un porta lavabo L 90 cm, P 54 cm, H 25 cm, art. PB290 laccato Bianco opaco, una base L 108 cm, P 54 cm, H 25 cm, art. PB2108 in essenza Rovere sbiancato. I lavabi art. URNAMOOD, sono in Flumood, la rubinetteria è BIKAPPA finitura lucida, art. BK200N. Lo specchio art. SFOGLIA75 con cornice Rovere sbiancato è L 75 cm, H 153 cm.

*The composition includes three cabinets, one sink unit L 72 cm, D 54 cm, H 50 cm in Rovere sbiancato art. PA272, a sink unit L 90 cm, D 54 cm, H 25 cm, art. PB290 lacquered matt Bianco, a cabinet L 108 cm, D 54 cm, H 25 cm, art. PB2108 in Rovere sbiancato. The sinks art. URNAMOOD, in Flumood, BIKAPPA polished finish tap art. BK200N. Mirror art. SFOGLIA75 with frame in Rovere sbiancato L 75 cm, H 153 cm.*





Composizione con mobile art. PA3180, L 180 cm, H 50 cm, P 40 cm, laccato Bianco lucido, con zoccolo laccato Nero gofrato art. PZ40 e pannello posteriore art. PPA180. I lavabi art. TENDERSG sono in Pietra Stone Grey. Rubinetteria BIKAPPA art. BK902N.

*Composition with cabinet art. PA3180, L 180 cm, H 50 cm, D 40 cm lacquered glossy Bianco with plinth lacquered embossed Nero art. PZ40 and back panel art. PPA180. The sinks art. TENDERSG are in Stone Grey. BIKAPPA tap art. BK902N.*

## PANTA REI design Carlo Colombo

Prof. 40/47/54

### PANTA REI

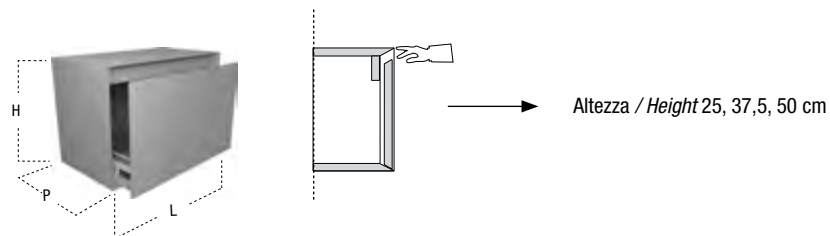

- Soluzione 1 cassetto con apertura superiore
- Solution with 1 upper opening drawer.

### PANTA REI CENTRO

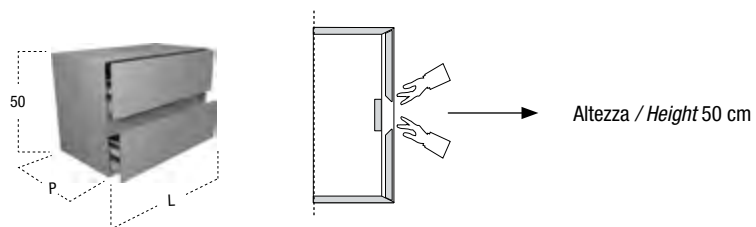

- Soluzione 2 cassetti con apertura centrale.
- Solution with 2 center opening drawers.

### PANTAREI XL

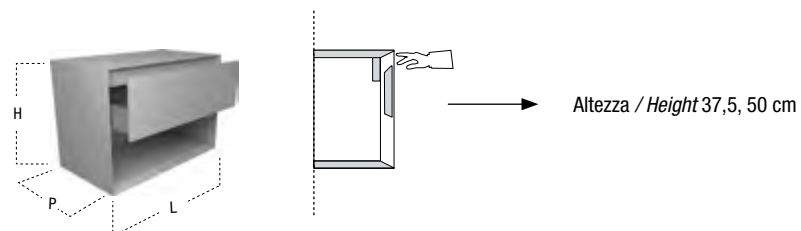

- Soluzione 1 cassetto con apertura superiore e 1 vano a giorno.
- Solution with 1 upper opening drawer and 1 open compartment.

### PANTAREI DOBLE

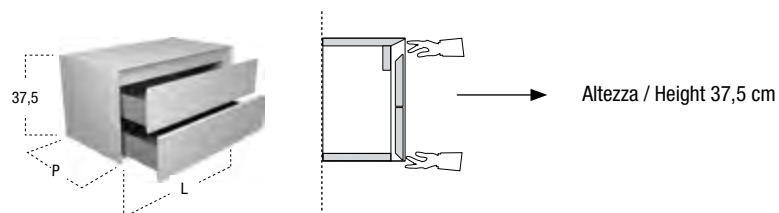

- Soluzione 2 cassetti con apertura superiore ed inferiore.
- Solution with 2 drawers 1 upper opening and 1 bottom opening.

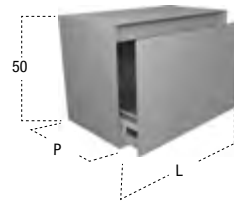
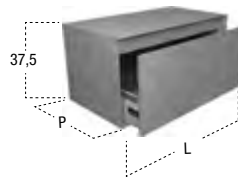
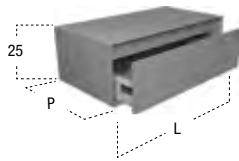

H L

25 36 / 45 / 54 / 72 / 90 / 108

37,5 36 / 45 / 54 / 72 / 90 / 108

50 36 / 45 / 54 / 72 / 90 / 108

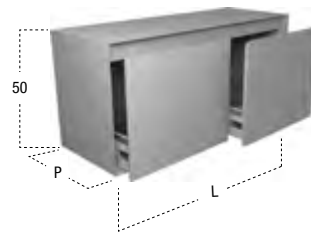
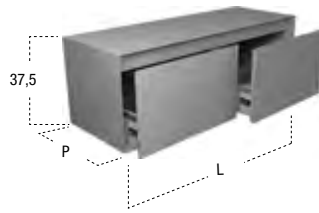
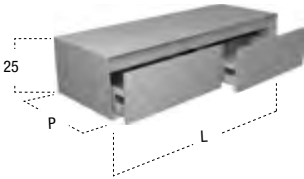

H L

25 72 (36+36) / 90 (45+45) / 108 (54+54) / 144 (72+72) / 180 (90+90) / 216 (108+108)

37,5 72 (36+36) / 90 (45+45) / 108 (54+54) / 144 (72+72) / 180 (90+90) / 216 (108+108)

50 72 (36+36) / 90 (45+45) / 108 (54+54) / 144 (72+72) / 180 (90+90) / 216 (108+108)

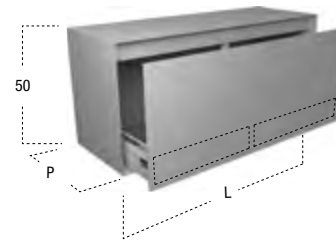
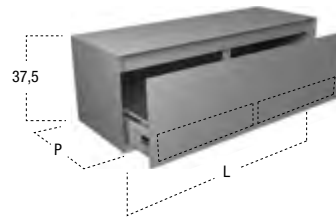
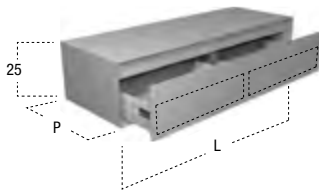

H L

25 144 (72+72) / 180 (90+90)

37,5 144 (72+72) / 180 (90+90)

50 144 (72+72) / 180 (90+90)

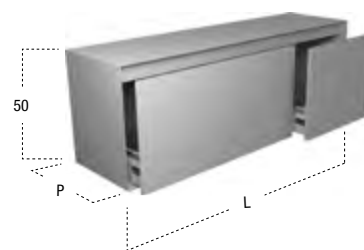
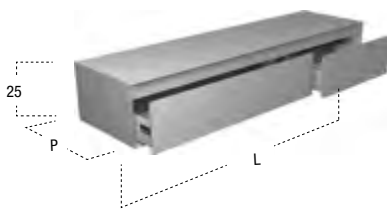

H L

25 108 (72+36) / 126 (72+54) / 135 (90+45) / 144 (90+54) / 144 (108+36) / 162 (90+72) / 162 (108+54)

37,5 108 (72+36) / 126 (72+54) / 135 (90+45) / 144 (90+54) / 144 (108+36) / 162 (90+72) / 162 (108+54)

50 108 (72+36) / 126 (72+54) / 135 (90+45) / 144 (90+54) / 144 (108+36) / 162 (90+72) / 162 (108+54)

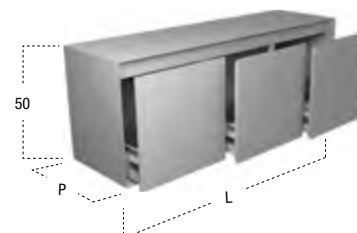
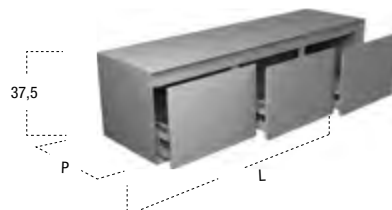

H L

25 108 (36+36+36) / 135 (45+45+45) / 162 (54+54+54) / 216 (72+72+72)

37,5 108 (36+36+36) / 135 (45+45+45) / 162 (54+54+54) / 216 (72+72+72)

50 108 (36+36+36) / 135 (45+45+45) / 162 (54+54+54) / 216 (72+72+72)

# PANTA REI

Prof. 40/47/54

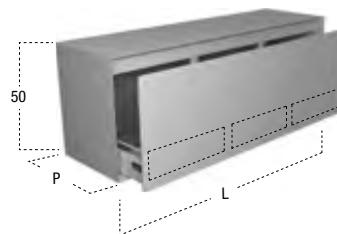
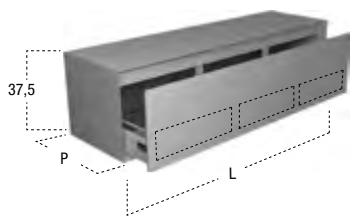
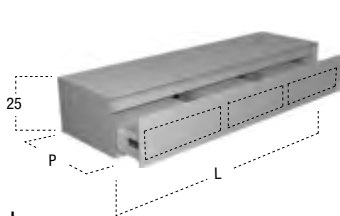

H	L
25	135 (45+45+45) / 162 (54+54+54)
37,5	135 (45+45+45) / 162 (54+54+54)
50	135 (45+45+45) / 162 (54+54+54)

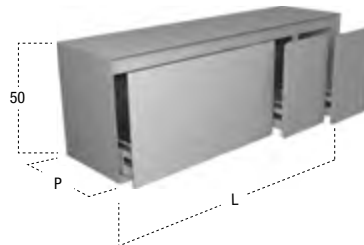
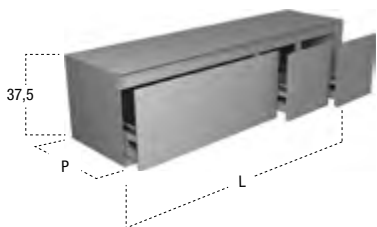
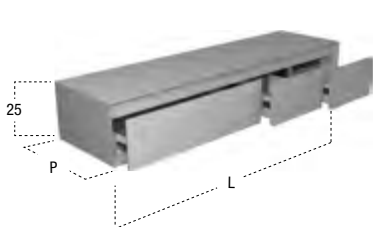

H	L
25	144 (72+36+36) / 162 (90+36+36) / 180 (90+45+45) / 180 (108+36+36) / 216 (108+54+54)
37,5	144 (72+36+36) / 162 (90+36+36) / 180 (90+45+45) / 180 (108+36+36) / 216 (108+54+54)
50	144 (72+36+36) / 162 (90+36+36) / 180 (90+45+45) / 180 (108+36+36) / 216 (108+54+54)

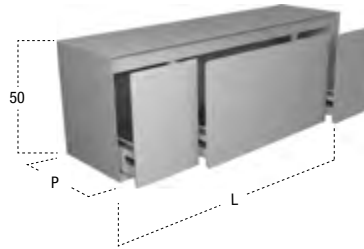
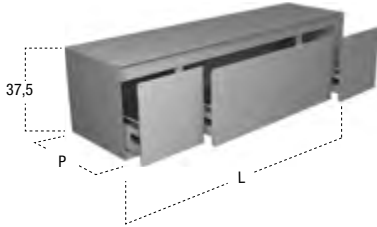
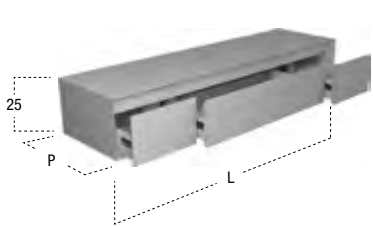

H	L
25	144 (36+72+36) / 162 (36+90+36) / 180 (45+90+45)
37,5	144 (36+72+36) / 162 (36+90+36) / 180 (45+90+45)
50	144 (36+72+36) / 162 (36+90+36) / 180 (45+90+45)

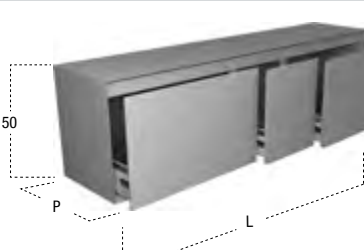
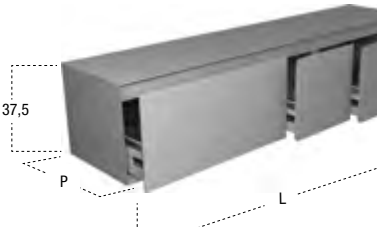

H	L
25	180 (72+36+72) / 216 (90+36+90)
37,5	180 (72+36+72) / 216 (90+36+90)
50	180 (72+36+72) / 216 (90+36+90)

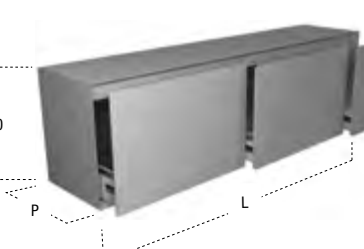
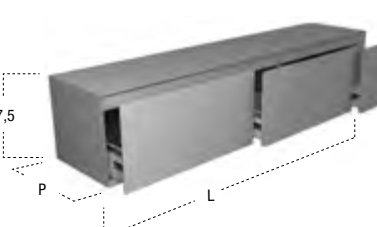
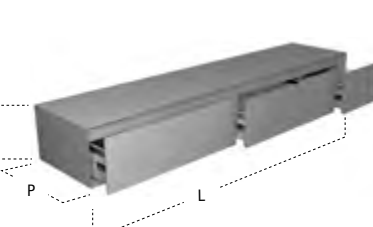

H	L
25	180 (72+72+36) / 216 (90+90+36)
37,5	180 (72+72+36) / 216 (90+90+36)
50	180 (72+72+36) / 216 (90+90+36)



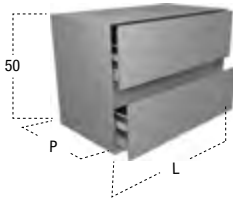

H	L
50	36 / 45 / 54 / 72 / 90 / 108

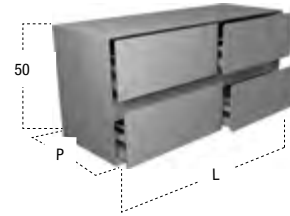

H	L
50	72 (36+36) / 90 (45+45) / 108 (54+54)
	144 (72+72) / 180 (90+90) / 216 (108+108)

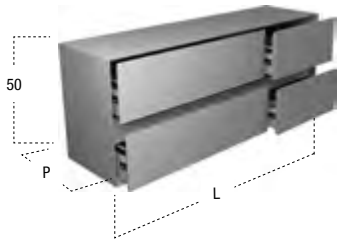

H	L
50	108 (72+36) / 126 (72+54) / 135 (90+45)
	144 (90+54) / 144 (108+36) / 162 (90+72) / 162 (108+54)

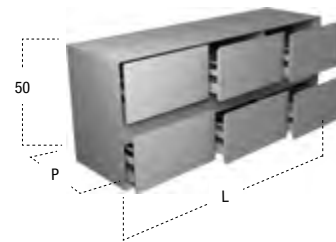

H	L
50	108 (36+36+36) / 135 (45+45+45) / 162 (54+54+54) / 216 (72+72+72)

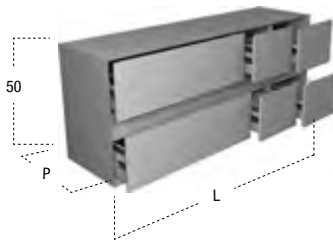

H	L
50	144 (72+36+36) / 162 (90+36+36) / 180 (90+45+45)
	180 (108+36+36) / 216 (108+54+54)

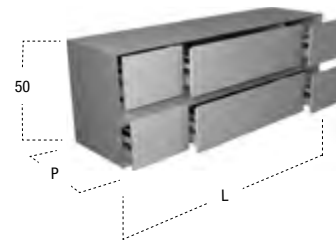

H	L
50	144 (36+72+36) / 162 (36+90+36) / 180 (45+90+45)

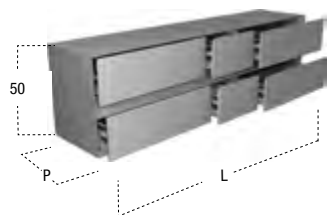

H	L
50	180 (72+36+72) / 216 (90+36+90)

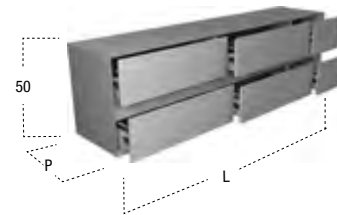

H	L
50	180 (72+72+36) / 216 (90+90+36)

In fase di ordine indicare il tipo di composizione scegliendo la lettera di riferimento (A,B,C,D,E,F,G), le misure dei componenti e la versione desiderata. Il mobile verrà composto in azienda e arriverà al cliente già montato come da soluzione scelta. Di seguito troverete un esempio esplicativo di come ordinare un mobile appartenente alla soluzione D. Le soluzioni A e B possono essere utilizzate con lavabi a parete, con lavabi da terra, oppure possono essere inseriti singolarmente in spazi living.

Specify at time of order the type of configuration among the proposed solutions (A,B,C,D,E,F,G) together with desired size of units and selected category. The modules will be assembled at the company and will be delivered to the client as per selected configuration. Find below an example of how to order one configuration belonging to solution D. Solution A and B are suitable for wall-mounted sinks, freestanding sinks or can be placed as an independent unit in a living room.

ESEMPIO MOBILE DA ORDINARE - EXAMPLE OF CONFIGURATION TO ORDER

**D** SOLUZIONE - CONFIGURATION

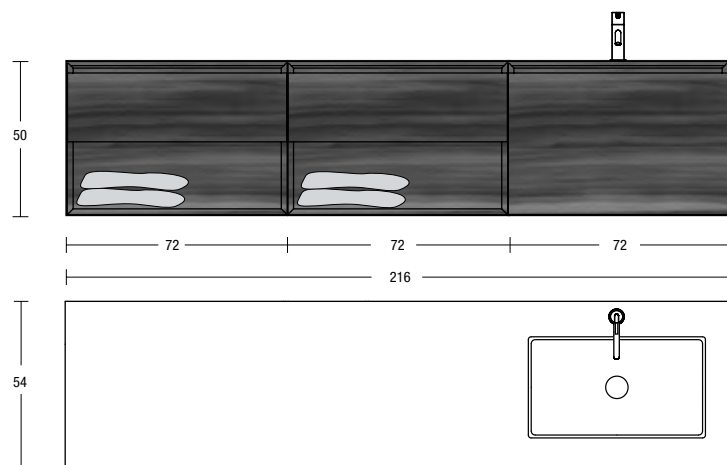

VERSIONE DX - Right version



N° 2 ART. PA4872 L 72

Base con 1 cassetto e 1 vano a giorno  
Cabinet with 1 drawer and 1 open compartment

+



ART. PA4672 L 72

Portalavabo con 1 cassetto  
Sink unit with 1 drawer

+

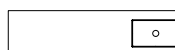

ART. BC254 + ART. NIDO L 216

Top con lavabo integrato  
Top with integrated sink

+



ART. AY301SA/AY301LU

Miscelatore monocomando  
Single lever mixer

SOLUZIONI LIVING - LIVING CONFIGURATIONS

**A**

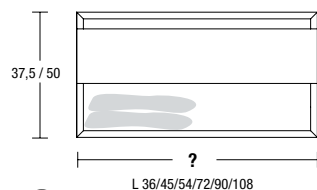

Base con 1 cassetto e 1 vano a giorno  
Cabinet with 1 drawer and 1 open compartment



**B**

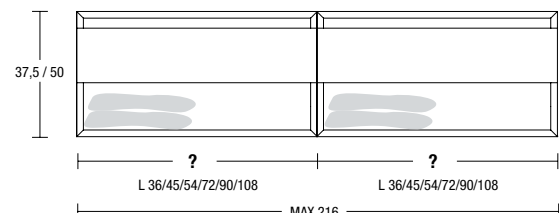

Base con 1 cassetto e 1 vano a giorno  
Cabinet with 1 drawer and 1 open compartment

Base con 1 cassetto e 1 vano a giorno  
Cabinet with 1 drawer and 1 open compartment



+



SOLUZIONI CON PORTALAVABO - CONFIGURATIONS WITH SINK UNIT

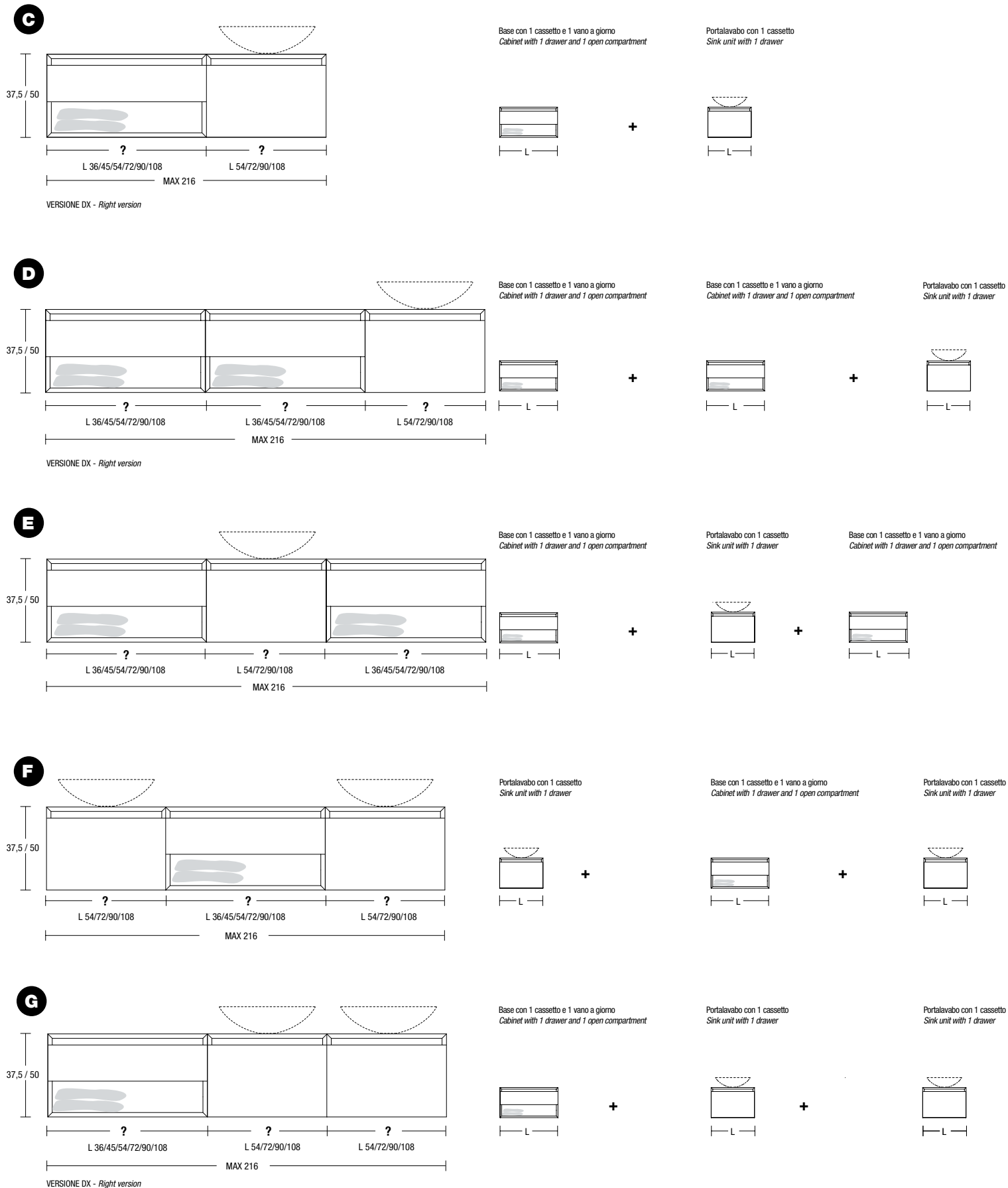

# PANTA REI DOBLE design Carlo Colombo

Prof. 40/47/54

In fase di ordine indicare il tipo di composizione scegliendo la lettera di riferimento (A,B,C,D,E,F,G), le misure dei componenti e la versione desiderata. Il mobile verrà composto in azienda e arriverà al cliente già montato come da soluzione scelta. Di seguito troverete un esempio esplicativo di come ordinare un mobile appartenente alla soluzione D. Le soluzioni A e B possono essere utilizzate con lavabi a parete, con lavabi da terra, oppure possono essere inseriti singolarmente in spazi living.

*Specify at time of order the type of configuration among the proposed solutions (A,B,C,D,E,F,G) together with desired size of units and selected category. The modules will be assembled at the company and will be delivered to the client as per selected configuration. Find below an example of how to order one configuration belonging to solution D. Solution A and B are suitable for wall-mounted sinks, freestanding sinks or can be placed as an independent unit in a living room.*

## ESEMPIO MOBILE DA ORDINARE - EXAMPLE OF CONFIGURATION TO ORDER

### **D** SOLUZIONE - CONFIGURATION

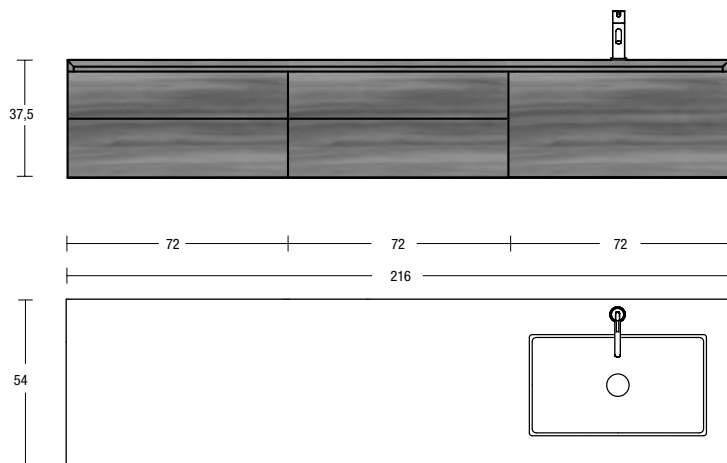

VERSIONE DX - Right version

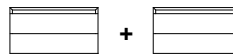

N° 2 ART. PI5672 L 72

Base con 2 cassetti  
Double drawer cabinet



+  
ART. PI5472 L 72

Portalavabo con 1 cassetto  
Sink unit with 1 drawer

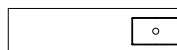

+  
ART. BC254 + ART. NIDO L 216

Top con lavabo integrato  
Top with integrated sink



+  
ART. AY301SA/AY301LU

Miscelatore monocomando  
Single lever mixer

## SOLUZIONI LIVING - LIVING CONFIGURATIONS

### **A**

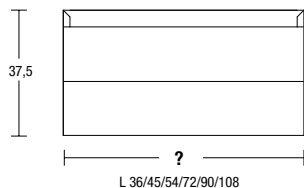

Base con 2 cassetti  
Double drawer cabinet



### **B**

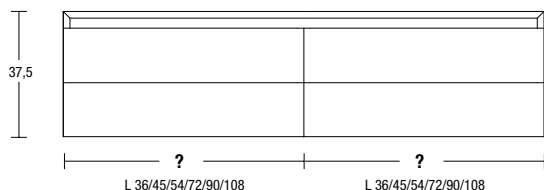

Base con 2 cassetti  
Double drawer cabinet



Base con 2 cassetti  
Double drawer cabinet



SOLUZIONI CON PORTALAVABO - CONFIGURATIONS WITH SINK UNIT

PANTA REI

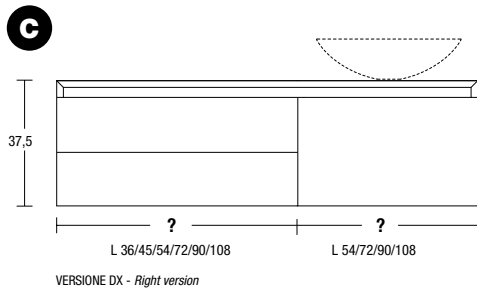

Base con 2 cassetti  
Double drawer cabinet



Portalavabo con 1 cassetto  
Sink unit with 1 drawer



+

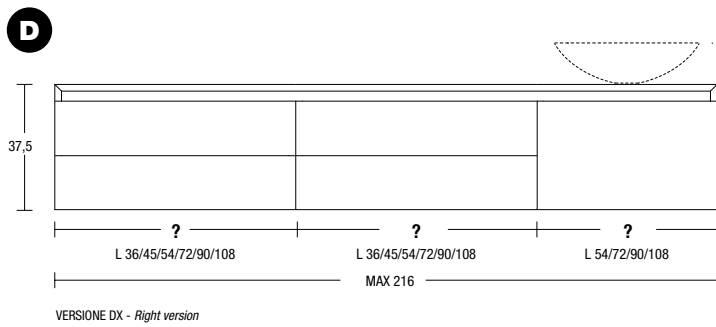

Base con 2 cassetti  
Double drawer cabinet



Base con 2 cassetti  
Double drawer cabinet



Portalavabo con 1 cassetto  
Sink unit with 1 drawer



+

+

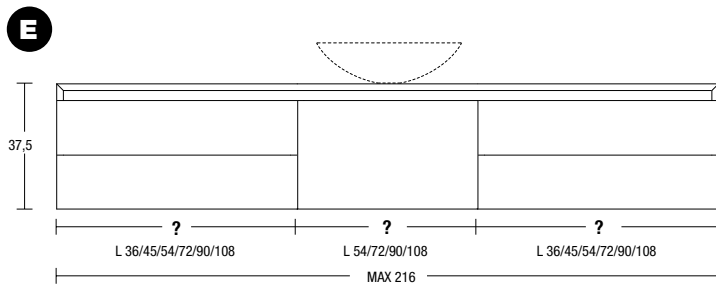

Base con 2 cassetti  
Double drawer cabinet



Portalavabo con 1 cassetto  
Sink unit with 1 drawer



Base con 2 cassetti  
Double drawer cabinet



+

+

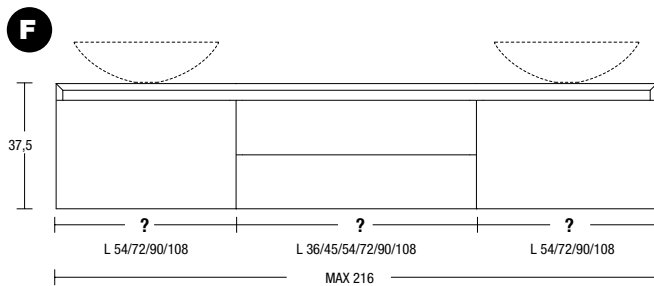

Portalavabo con 1 cassetto  
Sink unit with 1 drawer

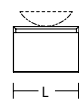

Base con 2 cassetti  
Double drawer cabinet



Portalavabo con 1 cassetto  
Sink unit with 1 drawer

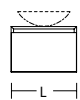

+

+

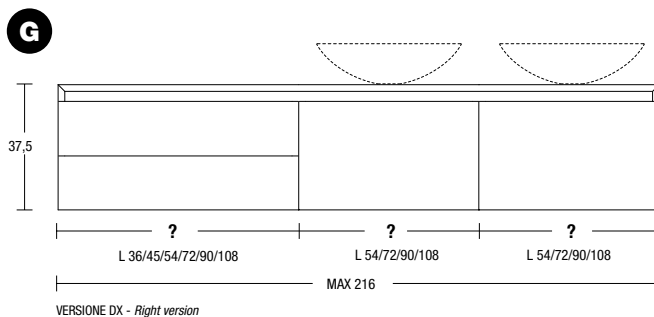

Base con 2 cassetti  
Double drawer cabinet



Portalavabo con 1 cassetto  
Sink unit with 1 drawer



Portalavabo con 1 cassetto  
Sink unit with 1 drawer



+

+

## PIANA design Nevio Tellatin

Design essenziale e misurato, capacità di essere allo stesso tempo complemento e protagonista, di esaltare le forme delle altre collezioni attraverso un design “silenzioso” ed efficace.

Razionale. Si potrebbe sintetizzare così Piana, la collezione disegnata da Nevio Tellatin rispondendo a una richiesta di “normalità” da parte dell’azienda. Una normalità sempre esclusiva, una semplicità formale sempre preziosa, un’immagine amica e conosciuta, con la gola a determinare l’apertura delle ante e a semplificare fin da subito le operazioni di apertura e chiusura.

Una collezione che trova il giusto posto nel mercato, sottolineando come dietro a una collezione di design ci sia una saggezza costruttiva che spesso viene dimenticata. Il mobile è realizzato partendo da un “nucleo” che potremo definire tecnico, realizzato in supporto laminato, e da una “pelle” esterna in legno, laccata o con possibili rivestimenti con altri materiali. Una tecnica costruttiva che lascia spazio a numerose combinazioni sia di finiture, che tipologiche, premesse di ulteriori sviluppi, un modus operandi che identifica Piana quale portavoce di quella sartorialità che è nel dna dell’azienda.

*Essential and measured design with the ability to be both a complement or protagonist. To enhance the shapes of other collections through a “silent” and effective design.*

*Rational, the collection designed by Nevio Tellatin responded to a request for “normality” by the company. An increasingly valuable simplicity with a known image. A determined space for the opening of the doors and drawers.*

*A collection that found its place in the market, underlining that behind a collection of design there is constructive wisdom that is often forgotten. The cabinet is made starting from a laminated “core”, and can be covered in wood or lacquered with different possible coatings. A construction technique that allows for numerous combinations of both finishes, for further development in a way that identifies Piana as spokesman for the tailor made in the DNA of the company.*



PIANA

LE NUOVE CARATTERISTICHE DI UNA COLLEZIONE DI SUCCESSO / *THE NEW FEATURES OF A SUCCESSFUL COLLECTION:*



STRUTTURA INTERNA SKIN CENERE

INTERNAL STRUCTURE SKIN CENERE



LEGNO MULTISTRATO BETULLA E CASSETTI SLIM

MULTILAYER BIRCH WOOD AND SLIM DRAWERS





PIANA

POSSIBILITÀ DI SCELTA TRA TUTTE LE ESSENZE DEL NOSTRO CAMPIONARIO

*POSSIBILITY OF CHOOSING AMONGST ALL OUR WOOD ESSENCES*



La composizione L 218,4 cm, P 54 cm, H 50 cm, laccata Matita goffrato, è composto da due fianchi art. IFA54, da un porta lavabo con due ante L 72 cm art. IL5472, da una base con due cassetti L 72 cm art. IB472, e da due basi con anta L 36 cm art. IB5236. Il top è in Flumood Satin art. BC154, con lavabo integrato art. NIDO e rubinetteria AYATI in finitura satinata art. AY200SA. Lo specchio L 216 cm, H 75 cm, con illuminazione a led luce bianca è art. FLASH75W.

*The composition L 218,4 cm, D 54 cm, H 50 cm lacquered embossed Matita, is made up of two side panels art. IFA54 a double door sink unit L 72 cm art. IL5472, a double drawer cabinet L 72 cm art. IB472, two cabinets L 36 cm art. IB5236. The Flumood Satin top art. BC154 with integrated sink art. NIDO and satin AYATI tap art. AY200SA. The mirror is L 216 cm, H 75 cm white LED lighting art. FLASH75W.*



PIANA





PIANA



I due mobili gemelli nella foto, realizzati in Rovere thermo, sono entrambi composti da due fianchi art. IFI47, un porta lavabo con cassetto art. ILIM290, una base con cassetto art. IBIM245, nella quale è stato inserito un cassetto opzionale art. SLIM40. Il top art. BC147, con lavabo integrato art. BASICO47 è in Flumood Satin, L 137,4 cm P 47 cm, spessore 12 mm. Il rubinetto della serie BIKAPPA è l'art. BK400N, gli specchi sono entrambi art. CIRCUS120W. L'attrezzatura dei cassetti è della collezione STRATO.

*The two twin cabinets in the photo, in Rovere thermo, are both made up of two sides panel art. IFI47, a sink unit with drawer art. ILIM290, a cabinet with drawer art. IBIM245 where an internal drawer was added art. SLIM40. The top art. BC147 with integrated sink art. BASICO47 is in Flumood Satin, L 137,4 cm D 47 cm, thickness 12 mm. BIKAPPA tap art. BK400N, the mirrors are both art. CIRCUS120W. The internal drawer accessories are STRATO.*



PIANA







PIANA



Lo specchio con illuminazione a led corredato di lampada LUCENTE è un art. CIRCUS1108W Ø 108 cm. Il mobile in finitura Rovere thermo L 182,4 cm, P 54 cm, H 37,5 cm è composto da due fianchi art. IFI54, una base portalavabo art. ILI290 e una base art. IBI290. Il top con lavabo integrato art. NUVQ190 è in Quarzomood color Terra, la rubinetteria è INDIGO art. ND301GR finitura grafite.

*The mirror with led lighting and lamp LUCENTE is art. CIRCUS1108W Ø 108 cm. The cabinet is in Rovere thermo L 182,4 cm D 54 cm, H 37,5 cm, made up of two end panels art. IFI54, a sink unit art. ILI290 and a cabinet art. IBI290. The top with integrated basin art. NUVQ190 is in Quarzomood Terra color, tap series is INDIGO art. ND301GR graphite finish.*



PIANA



ZENITLED



ZENITLED



PIANA





Il mobile in Noce canaletto è composto da due basi portalavabo art. IL1872, L 72 cm, P 54 cm, H 50 cm ciascuna e una base art. IB872, L 72 cm, P 54 cm, H 50 cm, a chiusura due fianchi art. IFA54, P 54 cm, H 50 cm. Il top di spessore 12 mm è in Quarzomood color Seta. I lavabi sono due art. STRATOS3 mentre la rubinetteria AYATI in acciaio lucido è art. AY921LU e art. AY600LU.

*Furniture in Noce canaletto made up of two sink units art. IL1872, L 72 cm, D 54 cm, H 50 cm each and one cabinet art. IB872, L 72 cm, D 54 cm, H 50 cm, finishing panel on either side art. IFA54, D 54 cm, H 50. The top is in Quarzomood 12 mm thick colour Seta. Two sinks art. STRATOS3 and AYATI tap series art. AY921LU and art. AY600LU in polished stainless steel.*



PIANA

Top in Quarzomood colore Seta

Quarzomood top colour Seta







PIANA





PIANA





PIANA

Specchio L 180 cm, H 75 cm art. NEUTROLED75W, mobile laccato Tortora lucido, composto da due porta lavabi con cassetto L 72 cm, art. ILI272, una base con cassetto L 36 cm art. IBI236 e una coppia di fianchi art. IFI54, per una lunghezza complessiva di L 182,4 cm, P 54 cm, H 37,5 cm. Il top è in Flumood finitura Satin art. BC154, con doppio lavabo integrato art. NIDO, la rubinetteria è BIKAPPA finitura lucida art. BK400N.

*Mirror L 180 cm, H 75 cm art. NEUTROLED75W, cabinet lacquered glossy Tortora made up of two single drawer sink units L 72 cm, art. ILI272, a single drawer module L 36 cm art. IBI236 and side panels art. IFI54 - total L 182,4 cm, D 54 cm, H 37,5 cm.*

*Satin Flumood top art. BC154 with two integrated sinks art. NIDO, polished BIKAPPA tap art. BK400N.*





PIANA







PIANA

La composizione comprende un modulo di L 110,4 cm, P 47 cm e H 50 cm, laccato Bianco Mood lucido, è composta da un fianco art. IFA47, da un fianco a giorno con ripiano art. IFG247, e da un porta lavabo con due cassetti art. ILM490.

Il top in Flumood in finitura Satin art. BC147 con lavabo integrato art. BASICO47, completo di rubinetteria in finitura cromo lucido art. BK400N. Lo specchio art. VARIO100W L 108 cm, H 100 cm.

*The composition includes one cabinet L 110,4 cm, D 47 cm and H 50 cm lacquered glossy Bianco Mood and is made up of one side panel art. IFA47 an open side panel with shelve art. IFG247 and one sink unit with two drawers art. ILM490.*

*The top is in Flumood art. BC147 with integrated sink art. BASICO47 complete with polished chrome tap art. BK400N. The mirrors art. VARIO100W L 108 cm, H 100 cm.*





Il mobile nella foto di dimensioni L 164,4 cm, P 54 cm, H 37,5 cm, è composto da un fianco art. IFI54, una base con cassetto art. IBI272, un porta lavabo art. ILI272; a destra chiude la composizione un vano a giorno art. IFG154, finitura Bianco Mood lucido. Il top art. BC154, con lavabo integrato art. NUVOLA è in Flumood Satin, L 164,4 cm, P 54 cm, spessore 12 mm. Il rubinetto della serie BIKAPPA in finitura cromo lucido è l'art. BK400N, lo specchio con illuminazione a led completo di lampada LUCENTE è l'art. CIRCUS1108W. In appoggio sul top un vassoio in noce canaletto della collezione DOMINO.

*The composition in the photo measuring L 164,4 cm, D 54 cm, H 37,5 cm is made up of art. IFI54, a cabinet with drawer art. IBI272, a sink unit art. ILI272 and on the right side open shelves art. IFG154. Finish is glossy Bianco Mood. The top art. BC154 with integrated sink art. NUVOLA is in Flumood Satin, L 164,4 cm, D 54 cm thickness 12 mm. The polished chrome tap is from the BIKAPPA series art. BK400N, the mirror with led lighting complete with LUCENTE lamp is art. CIRCUS1108W. On the top of the cabinet a tray in Noce canaletto from collection DOMINO.*





La composizione L 182,4 cm, P 54 cm, H 37,5 cm, è formata da due fianchi art. IFI54, da un porta lavabo con cassetto L 72 cm, art. ILI272, da due basi con cassetto L 72 cm art. IBI272 e L 36 cm art. IBI236.

Il top è in Flumood finitura Satin, art. BC154 con lavabo integrato art. NUVOLA, la rubinetteria è BIKAPPA in finitura lucida art. BK400N. Di lato al mobile, due colonne L 27 cm, H 150 cm, P 14 cm, in vetro extrachiaro con schienale laccato Strada lucido, art. ICE3. Lo specchio è L 180 cm, H 50 cm, art. VARIO50W con interruttore art. MAGIC. Gli accessori sono della collezione PLAY, in acciaio inox AISI 304, finitura lucida.

*The composition L 182,4 cm, D 54 cm, H 37,5 cm is made up of two side panels art. IFI54, a single drawer sink unit L 72 cm art. ILI272, two single drawer cabinets L 72 cm art. IBI272 and L 36 cm art. IBI236; Flumood top in the Satin finish art. BC154 with integrated sink art. NUVOLA and polished BIKAPPA tap art. BK400N. On the side of the cabinet, two high cabinets L 27 cm, H 150 cm, D 14 cm in extrachiaro glass with lacquered back color glossy Strada, art. ICE3. Mirror is L 180 cm, H 50 cm, art. VARIO50W with switch art. MAGIC. Accessories from the PLAY series in polished stainless steel AISI 304.*





Specchio art. NEUTRO75, L 216 cm, sul quale è inserita la lampada art. LUCENTE216. Il mobile laccato Tortora lucido è composto da due porta lavabi con cassetto L 72 cm art. ILI272, una base con cassetto L 72 cm art. IBI272 e una coppia di fianchi art. IFI54, per una lunghezza complessiva di L 218,4 cm, P 54 cm e H 37,5 cm. Il top è in Flumood Satin art. BC154 con doppio lavabo integrato art. NUVOLA e rubinetteria BIKAPPA art. BK400N.

*Mirror art. NEUTRO75, L 216 cm, with lamp art. LUCENTE216. The cabinet is lacquered glossy Tortora and made up of two sink units with drawer L 72 cm art. ILI272, a cabinet with drawer L 72 cm art. IBI272 and a pair of end panels art. IFI54, for a total length of L218,4 cm, D 54 cm and H 37,5 cm. The top in Flumood Satin art. BC154 with double integrated sink art. NUVOLA and BIKAPPA tap art. BK400N.*





Lo specchio a filo lucido è art. NEUTROLED75W, L 216 cm, H 75 cm. Il top è in Flumood Satin art. BC154 con doppio lavabo integrato art. NIDO e rubinetteria della serie BIKAPPA art. BK400N.

*Polished edge mirror art. NEUTROLED75W, L 216 cm, H 75 cm. Satin Flumood top art. BC154 with two integrated sinks art. NIDO and tap BIKAPPA art. BK400N.*





PIANA





La composizione nella foto comprende, la rubinetteria AYATI in finitura acciaio lucido, composta da due art. AY921LU e da due art. AY600LU. I due lavabi in Flumood art. POGGIO su un top speciale in Corian di spessore 12 mm, L 389,4 cm, P 54 cm. Il mobile H 25 cm, è composto da due fianchi di finitura art. IFB54, da due porta lavabi art. ILB1472 di L 72 cm e da quattro basi con cassetto di cui una di L 54 cm art. IBB254, due di L 72 cm art. IBB272 e una di L 45 cm art. IBB245, la composizione termina a destra con la vasca in Corian art. BIBLIO103 speciale, completa di rubinetteria AYATI art. AY702LU.

*The composition in the picture has the AYATI taps are two AY921LU and two AY600LU polished stainless steel. The two sinks in Flumood art. POGGIO are on a custom made Corian top 12 mm thick L 389,4 cm and D 54 cm. The furniture H 25 cm is made up of two side panels art. IFB54, two sink units art. ILB1472 measuring L 72 cm and four cabinets with drawer, one measuring L 54 cm art. IBB254, two L 72 cm art. IBB272 and one L 45 cm art. IBB245. On the right a custom made Corian bathtub art. BIBLIO103 complete with AYATI tap art. AY702LU.*





PIANA

La composizione L 182,4 cm comprende, due specchi L 72 cm, H 100 cm art. FLASH100W. Il mobile è laccato color Grigio Smog goffrato, composto da due porta lavabi con doppia anta L 72 cm, P 54 cm, H 50 cm art. IL5472, da una base L 36 cm con due cassetti art. IB436 e da due fianchi art. IFA54. I lavabi sono in Ceramilux lucido, art. FOGLIO63 e poggiano sul top in vetro laccato Matita acidato art. IT2. La rubinetteria è AYATI art. AY302SA, in finitura satinata.

*The composition L 182,4 cm includes two mirrors L 72 cm, H 100 cm art. FLASH100W; lacquered cabinet color embossed Grigio Smog composed by two double door sink units L 72 cm, D 54 cm, H 50 cm art. IL5472, a double drawer cabinet L 36 cm art. IB436 and two side panels art. IFA54. Top mount glossy Ceramilux sinks art. FOGLIO63 on a glass top lacquered acid Matita art. IT2; satin AYATI tap art. AY302SA.*



La composizione L 182,4 cm comprende, uno specchio L 144 cm, H 75 cm art. FLASH75W. Il mobile è laccato Grigio Smog goffrato, composto da un porta lavabo con cassetto L 72 cm, P 54 cm, H 50 cm art. IL272, da due basi L 36 cm art. IB236, da una base con due cassette art. IB436 e da due fianchi art. IFA54. Il lavabo è in Ceramilux lucido, art. FOGLIO63 e poggia sul top in vetro laccato Grigio Smog lucido art. IT2. La rubinetteria è BIKAPPA art. BK200N, in finitura lucida.

*The composition L 182,4 cm includes a mirror L 144 cm, H 75 cm art. FLASH75W; the lacquered furniture color embossed Grigio Smog is composed by a single drawer sink unit L 72 cm, D 54 cm, H 50 cm art. IL272, two cabinets L 36 cm art. IB236, a double drawer cabinet art. IB436 and two side panels art. IFA54. Top mount glossy Ceramilux sinks art. FOGLIO63 on a glass top lacquered glossy Grigio Smog art. IT2; polished BIKAPPA tap art. BK200N.*





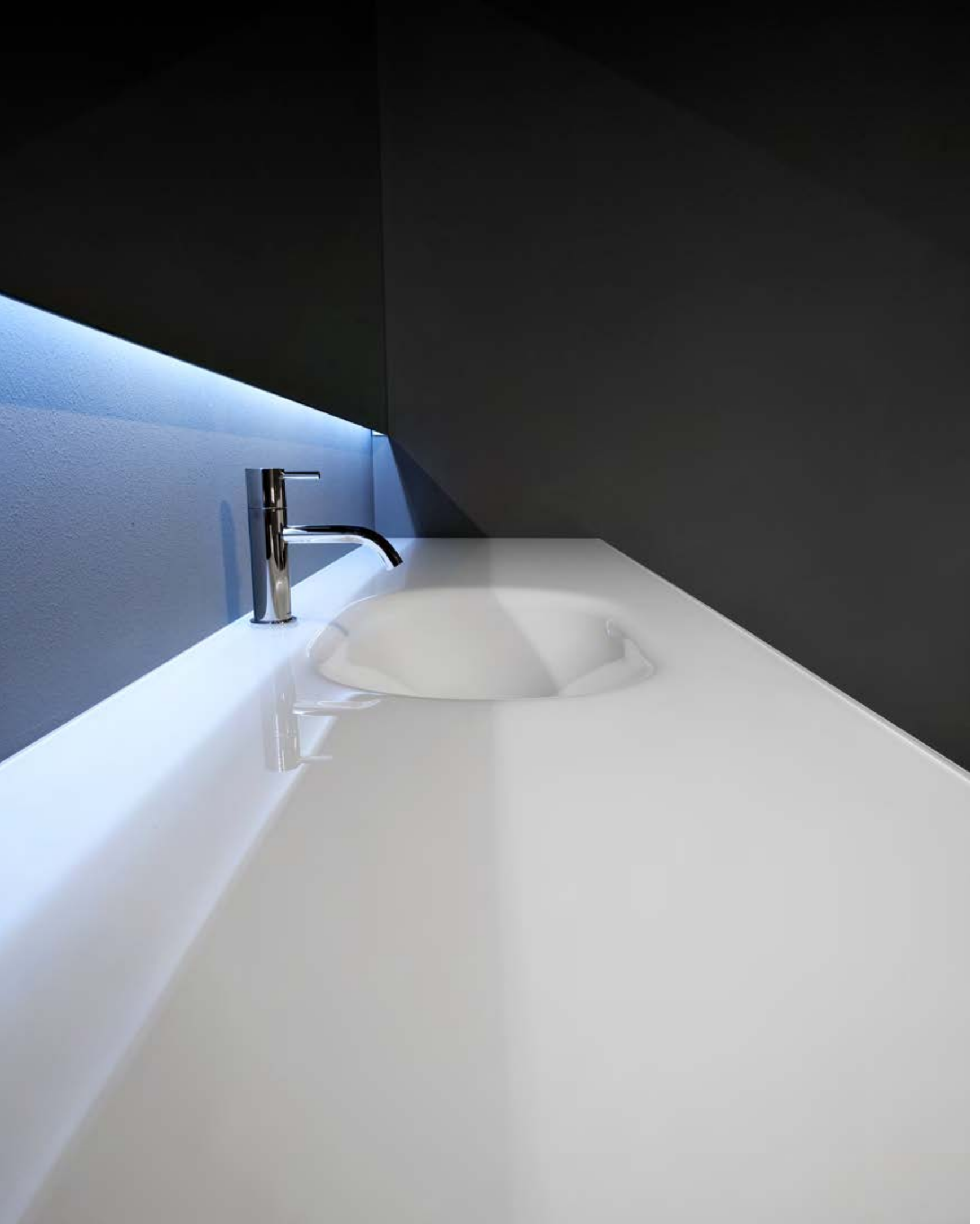



La composizione L 182,4 cm comprende, uno specchio L 180 cm, H 100 cm art. FLASH100W. Il mobile è laccato Bianco gofrato, composto da un porta lavabo con due cassetti di cui uno sagomato internamente per sifone, L 72 cm, P 54 cm, H 50 cm art. IL472, da tre basi L 36 cm, H 50 cm, P 54 cm art. IB5236, da due fianchi art. IFA54. Il top in vetro laccato Bianco lucido art. 910 con lavabo integrato art. SOAP72 è completo di rubinetteria AYATI art. AY301LU, in finitura lucida.

*The composition L 182,4 cm includes a mirror L 180 cm, H 100 cm art. FLASH100W; the lacquered cabinet color embossed Bianco is composed by a double drawer sink unit one of which internally shaped for siphon L 72 cm, D 54 cm, H 50 cm art. IL472, three modules L 36 cm, H 50 cm, D 54 cm art. IB5236 and two side panels art. IFA54. Glass top art. 910 in lacquered glossy Bianco, with integrated sink art. SOAP72 ; polished AYATI tap art. AY301LU.*





PIANA





La composizione L 218,4 cm, comprende uno specchio L 216 cm, H 75 cm, art. FLASH75W. Il mobile è laccato color Bianco lucido, composto da due porta lavabi con doppio cassetto, di cui uno sagomato internamente, art. IL472, L 72 cm, P 54 cm, H 50 cm; da una base, L 72 cm, H 50 cm, P 54 cm art. IB472 e da due fianchi art. IFA54.

I lavabi sono art. SERVO54 in Ceramilux lucido. Il top è in vetro spessore 8 mm Bianco laccato lucido art. IT2 e la rubinetteria è BIKAPPA art. BK200N, in finitura lucida.

*The composition L 218,4 cm includes a mirror L 216 cm, H 75 cm art. FLASH75W. The cabinet is lacquered glossy Bianco and is made up of two double drawer sink units, one of which internally shaped for siphon, art. IL472, L 72 cm, D 54 cm, H 50 cm; a cabinet L 72 cm, H 50 cm, D 54 cm art. IB472 and two side panels art. IFA54.*

*Glossy Ceramilux sink art. SERVO54; glass top 8 mm thick lacquered glossy Bianco art. IT2 and polished BIKAPPA tap art. BK200N.*







La composizione L 92,4 cm, comprende uno specchio L 54 cm, H 110 cm, art. NEUTRO110. Il mobile è laccato Bianco lucido, composto da un porta lavabo art. IL890, con fascia centrale, un frontale fisso e cassetto, L 90 cm, P 54 cm, H 50 cm e da due fianchi art. IFA54. Il top è in Flumood finitura Satin art. BC154, con lavabo integrato art. NIDO e la rubinetteria AYATI art. AY301LU, in finitura lucida.

*The composition L 92,4 cm includes a mirror L 54 cm, H 110 cm art. NEUTRO110. The cabinet is lacquered glossy Bianco and is made up of a sink unit art. IL890 with center panel, a fixed front and drawer, L 90 cm, P 54 cm, H 50 cm and two sides art. IFA54.*

*Satin Flumood top art. BC154 with integrated sink art. NIDO and polished AYATI tap art. AY301LU.*



La composizione L 146,4 cm, comprende uno specchio L 50 cm, H 108 cm, art. SPI05W. Il mobile è laccato Creta gofrato, composto da un porta lavabo con due ante art. IL5472, L 72 cm, P 54 cm, H 50 cm, da una base con doppio cassetto art. IB472 e da due fianchi art. IFA54. Il top è in Flumood finitura Satin art. BC154, con lavabo integrato art. NIDO e la rubinetteria è AYATI art. AY302LU, in finitura lucida.

*The composition L 146,4 cm includes a mirror L 50 cm, H 108 cm art. SPI05W. The cabinet, lacquered embossed Creta, is made up of a double door sink unit art. IL5472, L 72 cm, D 54 cm, H 50 cm, a double drawer module art. IB472 and two side panels art. IFA54. Flumood top satin finish art. BC154 with integrated sink art. NIDO and polished AYATI tap art. AY302LU.*





La composizione L 137,4 cm, comprende uno specchio L 135 cm, H 75 cm, art. SPI0675W. Il mobile è laccato Bianco goffrato, composto da un porta lavabo art. IL490 con due cassetti, di cui uno sagomato internamente, L 90 cm, P 54 cm, H 50 cm, da una base con doppio cassetto, art. IB445 L 45 cm, P 54 cm, H 50 cm e da due fianchi art. IFA54. Il top è in Flumood finitura Satin art. BC154, con lavabo integrato art. NIDO e la rubinetteria è AYATI art. AY302LU, in finitura lucida

*The composition L 137,4 cm includes a mirror L 135 cm, H 75 cm art. SPI0675W. The cabinet, lacquered embossed Bianco, is composed by a double drawer sink unit, one of which internally shaped for siphon, art. IL490, L 90 cm, D 54 cm, H 50 cm, a double drawer module art. IB445 L 45 cm, D 54 cm, H 50 and two side panels art. IFA54. Flumood top satin finish art. BC154 with integrated sink art. NIDO and polished AYATI tap art. AY302LU.*



La composizione L 182,4 cm, comprende uno specchio L 180 cm, H 75 cm, art. SPI0675W. Il mobile è laccato Grigio Pioggia goffrato, composto da un porta lavabo art. IL472 con due cassetti, di cui uno sagomato internamente, L 72 cm, P 54 cm, H 50 cm, da tre basi con doppio cassetto, art. IB436 L 36 cm, P 54 cm, H 50 cm e da due fianchi art. IFA54. Il top è in Flumood finitura Satin art. BC154, con lavabo integrato art. NIDO e la rubinetteria è AYATI art. AY302LU, in finitura lucida.

*The composition L 182,4 cm includes a mirror L 180 cm, H 75 cm art. SPI0675W. The cabinet, lacquered embossed Grigio Pioggia, is composed by a double drawer sink unit, one of which internally shaped for siphon, art. IL472, L 72 cm, D 54 cm, H 50 cm, three double drawer modules art. IB436 L 36 cm, D 54 cm, H 50 and two side panels art. IFA54.*

*Satin Flumood top art. BC154 with integrated sink art. NIDO and polished AYATI tap art. AY302LU.*





La composizione L 92,4 cm, comprende uno specchio L 90 cm, H 75 cm, art. SPI0675W. Il mobile è laccato Malta gofrato, composto da un porta lavabo con cassetto art. IL290, L 90 cm, P 54 cm, H 50 cm e da due fianchi art. IFA54. Il top art. IT2 è in vetro color Malta lucido, sopra il lavabo in Ceramilux lucido art. SERVORETTO63, la rubinetteria è BIKAPPA art. BK200N, in finitura lucida.

*The composition L 92,4 cm includes a mirror L 90 cm, H 75 cm art. SPI0675W. The cabinet, lacquered embossed Malta, is composed by a single drawer sink unit art. IL290, L 90 cm, D 54 cm, H 50 cm and two side panels art. IFA54. Glass top lacquered glossy Malta art. IT2, top mount glossy Ceramilux sink art. SERVORETTO63, polished BIKAPPA tap art. BK200N.*







La composizione L 182,4 cm, comprende uno specchio L 180 cm, H 75 cm, art. FLASH75W. Il mobile è laccato Bianco goffrato, composto da un porta lavabo art. IL290 con cassetto, L 90 cm, P 54 cm, H 50 cm, da due basi con doppio cassetto, art. IB445 L 45 cm, P 54 cm, H 50 cm e da due fianchi art. IFA54. Il top è in vetro, color Bianco lucido art. 910, con lavabo integrato art. SOAP72 e la rubinetteria è BIKAPPA art. BK300N, in finitura lucida.

*The composition L 182,4 cm includes a mirror L 180 cm, H 75 cm art. FLASH75W. The cabinet is lacquered embossed Bianco made up of a single drawer sink unit art. IL290, L 90 cm, D 54 cm, H 50 cm, two double drawer modules art. IB436 L 36 cm, D 54 cm, H 50 and two side panels art. IFA54. Lacquered glass top color glossy Bianco art. 910 with integrated sink art. SOAP72 and polished BIKAPPA tap art. BK300N.*

FIANCHI / SIDES

Prof. 40/47/54

Fianco da aggiungere a dx o a sx della composizione finale, formata da uno o più componenti di altezze diverse.  
Side panel to add one the right or left of the final composition made of one or more elements in different heights.

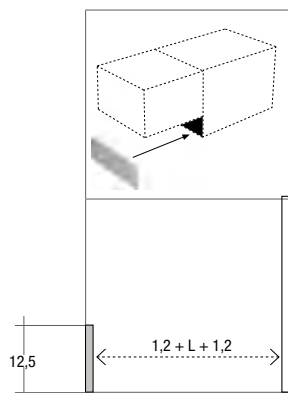

Fianco da aggiungere a dx o a sx della composizione finale, formata da uno o più componenti.  
Side panel to add one the right or left of the final composition made of one or more elements.

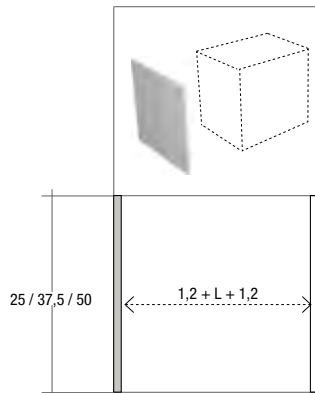

Fianco a giorno con 1 ripiano, da aggiungere a dx o sx della composizione finale, formata da uno o più componenti.  
Open side panel with 1 shelf to add on the right or the left final composition made up of one or more elements.

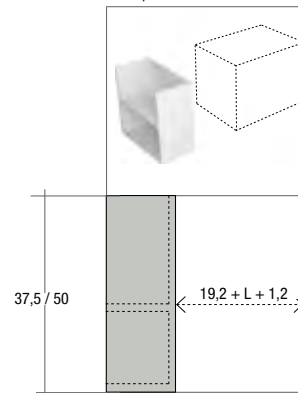

PORTA LAVABI E BASI CON FASCIA CENTRALE / SINK UNITS AND CABINETS WITH MIDDLE FRONT PANEL

Prof. 40/47/54

Porta lavabo con fascia centrale, 1 frontale fisso ed 1 cassetto.  
Sink unit with middle front panel, fixed front and 1 drawer.

Porta lavabo con fascia centrale, 2 cassetti di cui 1 sagomato internamente per sifone.  
Sink unit with middle front panel, 2 drawers of which 1 internally shaped for siphon.

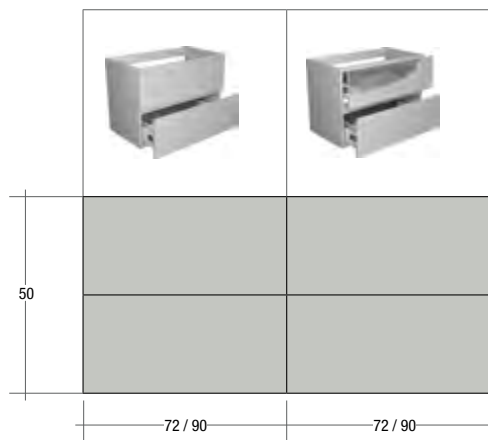

Base con fascia centrale e 2 cassetti.  
Cabinet with middle front panel and 2 drawers.

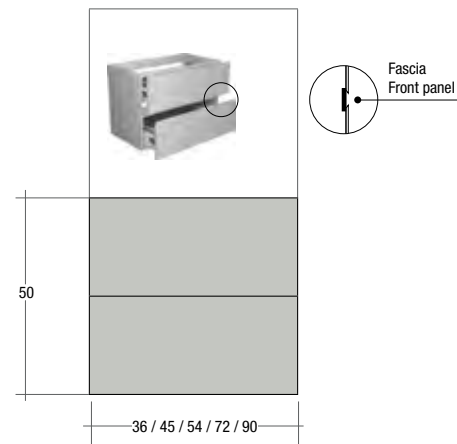

PORTA LAVABI E BASI CON FASCIA CENTRALE E SUPERIORE / SINK UNITS AND CABINETS WITH MIDDLE AND UPPER FRONT PANEL

Prof. 40/47/54

Porta lavabo con fascia superiore, centrale e 2 cassetti di cui 1 sagomato internamente per sifone.  
Sink unit with upper and middle front panel and 2 drawers 1 of which internally shaped for siphon.

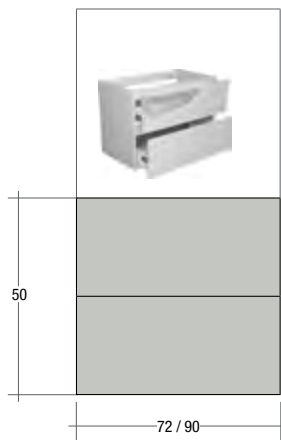

Base con fascia centrale, superiore e 2 cassetti.  
Cabinet with middle and upper front panel and 2 drawers.

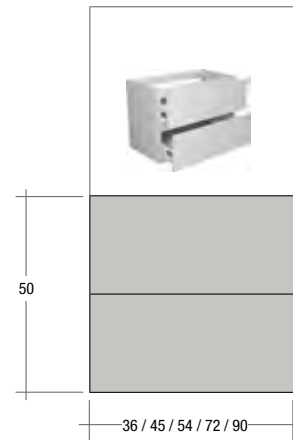

PORTA LAVABI CON FASCIA SUPERIORE / SINK UNITS WITH FRONT PANEL

Prof. 40/47/54

Porta lavabo con 1 cassetto ed il fondo sagomati internamente per sifone.  
Sink unit with 1 drawer and bottom shaped internally for siphon.

Porta lavabo con 1 cassetto.  
Large drawer sink unit.

Porta lavabo con 2 cassette di cui 1 sagomato internamente per sifone.  
Double drawer sink unit one of which internally shaped for siphon.

Porta lavabo dx o sx con 1 anta.  
Right or left single door sink unit.

Porta lavabo con 2 ante.  
Double door sink unit.

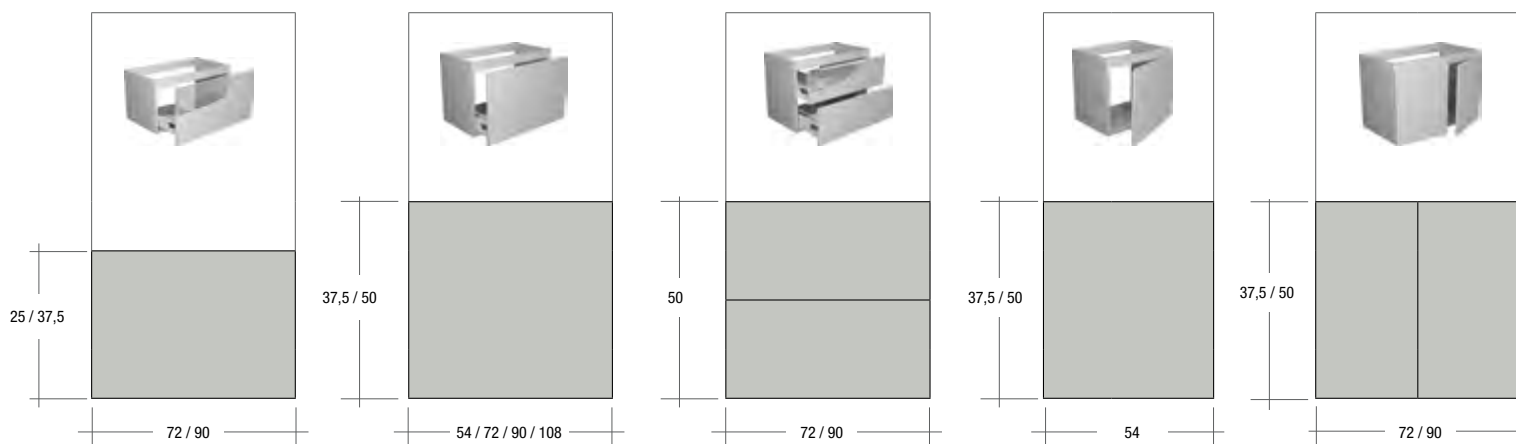

BASI CON FASCIA SUPERIORE / CABINETS WITH FRONT PANEL

Prof. 40/47/54

Base con 1 cassetto.  
Single drawer cabinet.

Base con 2 cassette.  
Double drawer cabinet.

Base dx o sx con 1 anta e 1 ripiano interno solo per H 50 cm.  
Right or left single door cabinet with 1 internal shelf only for H 50.

Base con 2 ante e 1 ripiano interno solo per H 50 cm.  
Double door cabinet with 1 internal shelf only for H 50.

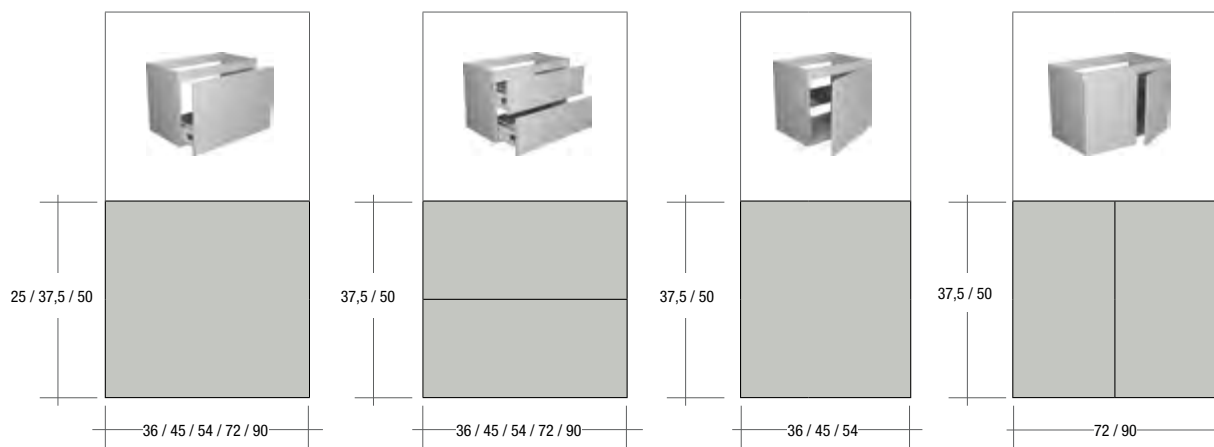

BASI CON VANI A GIORNO / OPEN CABINET WITH COMPARTMENTS

Prof. 40/47/54

Base con 1 vano a giorno  
Open cabinet with 1 compartment

Base con 2 vani a giorno  
Open cabinet with 2 compartments

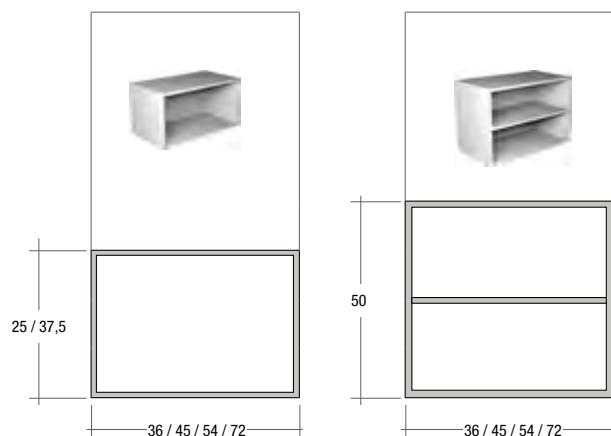

## ATELIER design Mario Ferrarini

Un programma ampio e articolato nella sua semplicità, una serie di mobili dal design pulito e rigoroso che offre molteplici possibilità di combinazione grazie all'utilizzo di pochissimi elementi. Atelier, la serie di mobili contenitori dalle linee essenziali disegnata da Mario Ferrarini, trova nell'anta l'elemento decorativo che esalta la composizione.

L'anta è composta da un profilo in alluminio con frontale in legno che a seconda di come viene posizionato all'interno del profilo, crea una gola o maniglia donando un segno grafico alla composizione.

La gola può essere posta in orizzontale totalmente o parzialmente rispetto allo sviluppo del mobile, ma anche collocata lungo i lati verticali o addirittura "incorniciare" i quattro lati, permette di personalizzare questa microarchitettura domestica conferendo profondità alla superficie.

Disponibile in tutte le essenze legno e in tutta la gamma colori laccati di antoniolupi, Atelier è una collezione sartoriale, come da dna dell'azienda e vive sulla combinazione di moduli di svariate dimensioni.

*A wide and articulated program in its simplicity, a series of furniture with a clean and rigorous design that offers multiple possibilities of combinations thanks to the use of very few elements. Atelier, the series of furniture with essential lines designed by Mario Ferrarini, with a decorative element in the door that enhances the composition.*

*The door is composed of an aluminum profile with a wooden front which, depending on how it is positioned inside the profile, creates a groove or handle donating a graphic sign to the composition.*

*The handle can be placed horizontally, totally or partially, with respect to the rest of the furniture, but also placed along the vertical sides or even "frame" the four sides allowing you to customize a domestic micro-architecture and give depth to the surface.*

*Available in all wood types and in the full range of antoniolupi lacquered colors, Atelier is a tailored collection, inspired by the company's DNA, based on a combination of modules in various sizes.*



ATELIER



## SISTEMA ATELIER

L'anta è composta da un profilo in alluminio con frontale in legno che a seconda di come viene posizionato all'interno del profilo crea una gola o maniglia donando un segno grafico alla composizione. La gola può essere posta in orizzontale totalmente o parzialmente rispetto allo sviluppo del mobile, ma anche collocata lungo i lati verticali o addirittura "incorniciare" i quattro lati, permette di personalizzare questa microarchitettura domestica conferendo profondità alla superficie.

È necessario scegliere la finitura dei frontali identificata dai numeri 3 e 4, la tipologia di maniglia identificata dalle lettere A-B-C-D-E-F-G-H e la finitura del telaio in alluminio bronzo-titanio-zirconio-champagne. La struttura è in finitura Skin cenere.

## ATELIER SYSTEM

The door is composed of an aluminum profile with a wooden front which, depending on how it is positioned creates a groove or handle donating a graphic sign to the composition.

The handle can be placed horizontally, totally or partially, with respect to the rest of the furniture, but also placed along the vertical sides or even "frame" the four sides allowing you to customize a domestic micro-architecture and give depth to the surface.

It is necessary to choose the finish of the fronts identified by numbers 3 and 4, the type of handle identified by the letters A-B-C-D-E-F-G-H and the finish of the aluminum frame in bronze-titanium-zirconium-champagne. The structure is in skin ash.

### MANIGLIE / HANDLES

### ESEMPI DI COMPOSIZIONI / COMPOSITION EXMPLES

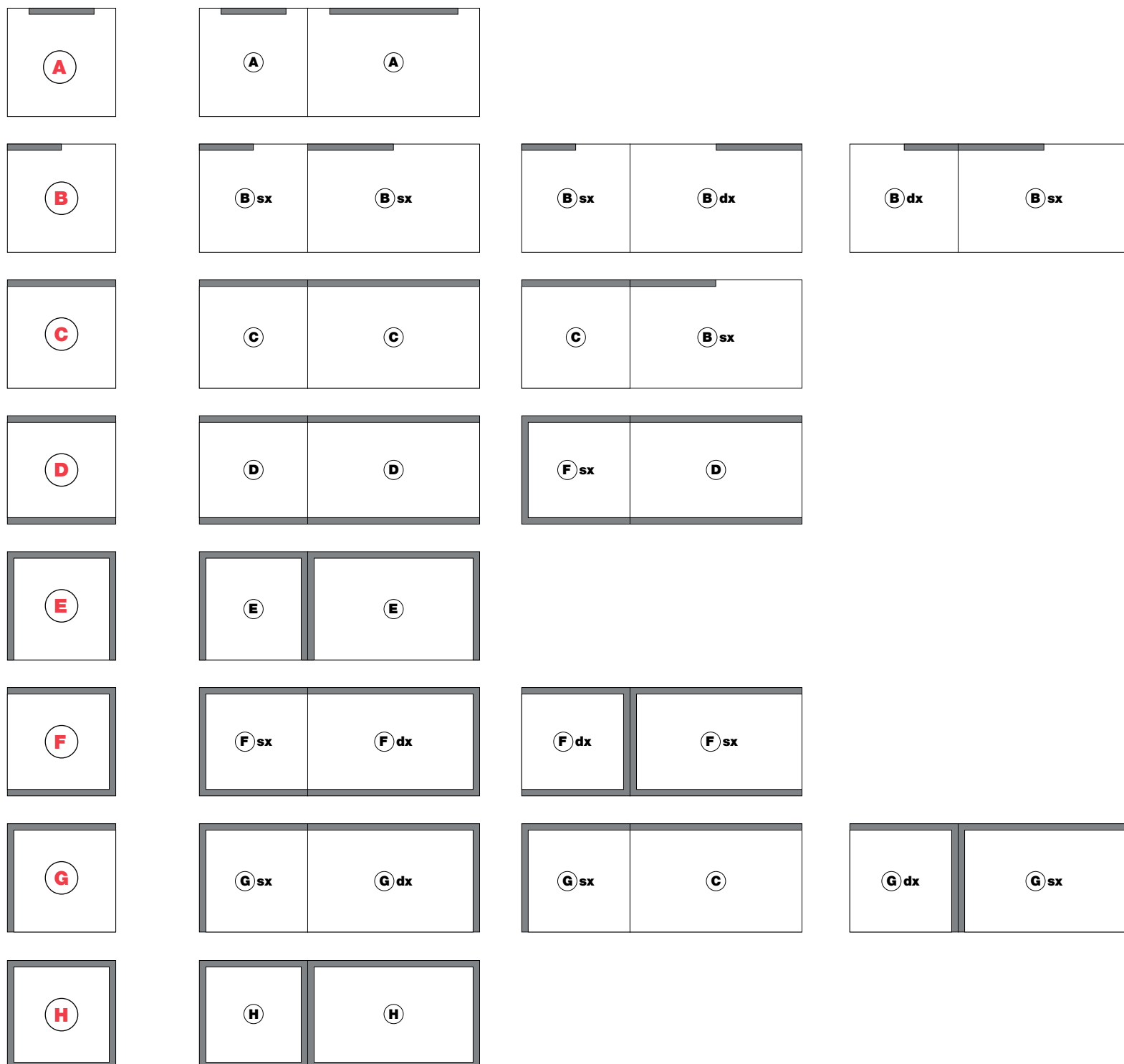









FIANCHI SKIN CENERE / SKIN CENERE SIDE PANELS



FIANCHI LACCATI / LAQUERED SIDE PANELS



ATELIER





Nella composizione abbiamo uno specchio art. CIRCUS1108W con illuminazione a led comprensivo di lampada LUCENTE, rubinetteria INDIGO art. ND301GR in finitura grafite. Il mobile L 162 cm, H 37,5 cm e P 54 cm con gola in orizzontale per tutta la lunghezza, è composto da un portalavabo art. ATIL2108, da una base art. ATIB254 e un top in Quarzomood con lavabo integrato colore Serena, art. NIDOQ172, con pianetto opzionale art. PIANETTOQ1; la struttura è Skin cenere, i profili sono in alluminio finitura titanio. I lati esterni del mobile sono in Noce canaletto art. ATL1. I frontali dei cassetti sono in Noce canaletto.

*The composition includes a mirror art. CIRCUS1108W with lamp LUCENTE, tap series INDIGO art. ND301GR in graphite finish. The furniture is L 162 cm H 37,5 and D 54 with horizontal handle along the entire length: sink unit art. ATIL2108, and cabinet art. ATIB254 with top in Quarzomood and integrated sink art. NIDOQ172 and optional cover art. PIANETTOQ1 in the Serena color. The structure of the cabinet is in Skin cenere, aluminum frame in the titanium finish, the external sides of the cabinets are in Noce canaletto and the fronts are in Noce canaletto.*





Nella foto; a parete due lampade art. BOLLA1 con specchio art. NEUTRO50 di L 144 cm, H 50 cm posizionato verticalmente. La composizione comprende inoltre un rubinetto INDIGO art. ND301GR in finitura grafite. Il mobile L 135 cm, H 37,5 cm e P 54 cm con gola in orizzontale per tutta la lunghezza, è composto da un portalavabo art. ATIL290, da una base art. ATIB245 e un top in Quarzomood con lavabo integrato colore Serena, art. NIDOQ172, con pianetto opzionale art. PIANETTOQ1; la struttura è Skin cenere, i profili sono in alluminio finitura bronzo. I lati esterni del mobile sono in Rovere thermo art. ATL1. I frontali dei cassetti sono in Rovere thermo.

*Above two lamps art. BOLLA1 with mirror art. NEUTRO50 L 144 cm, H 50 cm hung vertically. The composition also includes the tap INDIGO art. ND301GR in the graphite finish. The furniture L 135 cm, H 37,5 and D 54 cm with horizontal handle for the entire length is made up of a sink unit art. ATIL290, cabinet art. ATIB245 and a top in Quarzomood with integrated sink art. NIDOQ172 and optional cover art. PIANETTOQ1 in the Serena colour; the structure is in Skin cenere and aluminum frame in bronze finish. The external sides of the cabinets are in Rovere thermo art. ATL1, the fronts are in Rovere thermo.*







Nella foto lo specchio a sinistra è l'art. COLLAGE318, quello a destra è l'art. COLLAGE307, entrambi L 54 cm, H 75 cm. Le due composizioni, con rubinetti INDIGO art. ND301GR in finitura grafite, sono di L 135 cm, H 37,5 cm e P 47 e sono composte da un portalavabo art. ATILM290, da una base art. ATIBM245 e un top in Flumood Satin art. BC147 con lavabo integrato art. BASICO47; la struttura è Skin cenere, i profili sono in alluminio finitura champagne. I lati esterni del mobile sono laccati Blu Navy gofrato art. ATF1 come i frontali dei cassetti. Le due composizioni differiscono dalle posizioni delle gole.

*In the picture on the left art. COLLAGE318, the one on the right is art. COLLAGE307 both measuring L 54 cm, H 75 cm. The two compositions with INDIGO tap art. ND301GR in the graphite finish are L 135 cm, H 37,5 and D 47 cm made up of a sink unit art. ATILM290, two cabinets art. ATIBM245 and a top in Flumood satin art. BC147 with integrated sink art. BASICO47; the structure is in skin cenere the aluminum frame in champagne finish. The external sides of the cabinets are lacquered embossed Blu Navy art. ATF1 as the drawer fronts. The two compositions are different due to the position of the handles.*





ATELIER





Nella foto uno specchio art. COLLAGE309, L 54 cm, H 75 cm, rubinetto AYATI art. AY301LU in finitura acciaio lucido. Il mobile L 180 cm, H 37,5 cm e P 54 cm con gola ad "L", è composto da un portalavabo art. ATIL290, da due basi art. ATIB245 e un top in Quarzomood con lavabo integrato colore Seta, art. NIDOQ172, con pianetto opzionale art. PIANETTOQ1; la struttura è Skin cenere, i profili sono in alluminio finitura bronzo. I lati esterni del mobile sono laccati Ovatta goffrato art. ATF1. I frontali dei cassetti sono laccati Ovatta goffrato.

*In the photo a mirror art. COLLAGE309, L.54 cm, H.75 cm, AYATI tap art. AY301LU in polished steel. The furniture L 180 cm, H 37,5 cm and D 54 cm with handle in an "L" shape is made up of a sink unit art. ATIL290, two cabinets art. ATIB245 and a top in Quarzomood with integrated sink art. NIDOQ172 and optional cover art. PIANETTOQ1 in the Seta color. The structure is in skin cenere and the aluminum frame in bronze. The external sides of the cabinets are lacquered embossed Ovatta art. ATF1 and the fronts are lacquered embossed Ovatta.*

## PLANETA design Carlo Colombo

L'estrema pulizia formale e l'assenza di gole e maniglie sintetizzano un linguaggio contemporaneo che si integra perfettamente con i lavabi, per dar vita a un'immagine formale omogenea e sofisticata.

La cornice è il tratto distintivo di Planeta, un segno preciso, nitido e sottile che definisce un perimetro, quello del mobile, incorniciando le superfici per sottolinearne l'essenza per contrasto, oppure uniformandosi ad esse per annullare la dimensione dei volumi. Un perimetro sottile e nitido, generato dall'arretramento del filo dell'anta rispetto alla cassa del mobile. Un dettaglio tecnico che come spesso accade nelle collezioni di antoniolupi diventa espressione formale, un segno che determina continuità e contribuisce alla perfetta lettura del progetto.

Accostamenti forti o uniformità cromatica contribuiscono a determinare un'immagine completamente diversa del progetto. I contenitori dall'andamento fortemente longitudinale, si sviluppano in orizzontale o in verticale mantenendo quel carattere di leggerezza proprio di tutte le proposte dell'azienda. La sequenza articolata di più moduli accostati genera una composizione che impreziosisce lo spazio e lo "misura", oltre ad assolvere alle funzioni proprie di contenimento con metodo ed eleganza.

*The simplicity and absence of grooves and handles synthesize a contemporary language that integrates perfectly with washbasins giving life to a smooth and sophisticated formal image.*

*The frame is the distinctive trait of Planeta, a definite sharp and subtle sign that defines the perimeter of the cabinets to emphasize the essence for contrast. A thin and sharp perimeter, generated from the recession of the leaf doors with respect to the cabinet. A technicality, that often happens in the collections of antoniolupi, become a formal expression, and a sign that determines continuity.*

*Combinations or strong color consistency help to determine a completely different project.*

*The cabinets of the strongly longitudinal trend, can develop horizontally or vertically maintaining a lightness that is characteristic of all the company's proposals.*

*The articulated sequence of several modules combined creates a composition that embellishes the space as contains with method and elegance.*





Mobile di colore Cemento lucido di L 180 cm, P 47 cm, H 37,5 cm, art. LIM18180, presenta due cassetti L 72 cm e uno L 36 cm; specchio con cornice Cemento lucido art. SFOGLIA75L, L 180 cm. Top Flumood art. BC347 con due lavabi integrati art. BASICO47 in finitura Satin. Rubinetteria AYATI art. AY301LU finitura lucida.





*Cabinet lacquered glossy Cement L 180 cm, P 47 cm, H 37,5, art. LIM18180 made up of two drawers L 72 and one L 36 cm; mirror with frame lacquered glossy Cement art. SFOGLIA75L, L 180 cm. Flumood top art. BC347 with double integrated sinks model BASICO47 in satin finish. AYATI tap art. AY301LU polished.*





Cassetto interno opzionale art. SLIM40 e attrezzature STRATO con divisori in vetro fumè.

Internal optional drawer art. SLIM40 and accessories STRATO with dividers in fumè glass.









Mobile art. LIM10216, L 216 cm, H 37,5 cm, P 47 cm, color Matita lucido, con due specchi di cui uno art. NEUTROLED100W L 216 cm, H 100 cm e uno art. NTKIT50W L 216 cm, H 50 cm con rubinetteria AYATI art. AY921LU e art. AY600LU. Top in Flumood finitura Texture art. BCS54, lavabo da appoggio in Cristalplant art. SOLIDEA, con sifone in ottone art. MICRO finitura lucida.

*Cabinet art. LIM10216 L 216 cm, H 37,5 cm, P 47 cm lacquered glossy Matita, mirrors art. NEUTROLED100W L 216 cm, H 100 cm and one art. NTKIT50W L 216 cm, H 50 cm with AYATI taps art. AY921LU and art. AY600LU. Flumood top in Texture finish art. BCS54, Cristalplant top mount sink art. SOLIDEA with siphon art. MICRO polished.*







PLANETA

Nella foto a sinistra, le due composizioni sono formate entrambe da uno specchio art. FLASH75W L 135 cm, H 75 cm; rubinetteria BIKAPPA art. BK200N. Il mobile è l'art. LI66135 versione sinistra L 135 cm, P 54 cm, H 37,5 cm. Il lavabo sopra piano ad incasso in Ceramilux lucido e l'art. BULBO. In alto, top in Corian art. CR354 con lavabo integrato art. MYSLOT72.

*In the photo on the left the two compositions are both made up of a mirror art. FLASH75W L. 135 cm, H 75 cm; BIKAPPA tap art. BK200N. The cabinet art. LI66135 left version L 135 cm, D 54 cm, H 37,5 cm. The encased top mount sink is art. BULBO in glossy Ceramilux. Above, top in Corian art. CR354 with integrated sink model MYSLOT72.*



La composizione comprende uno specchio art. SPI0675W, L 180 cm, H 75 cm, un mobile L 180 cm, P 54 cm, H 37,5 cm art. LI22180, composto da quattro cassetti: tre L 36 cm e uno L 72 cm; lavabo in Ceramilux lucido art. PIPER1, rubinetteria della collezione BIKAPPA, art. BK200N.

*The composition is made up of a mirror art. SPI0675W, L 180 cm, H 75 cm, one cabinet, L 180 cm, P 54 cm, H 37,5 cm art. LI22180 with four drawers: three measure L 36 cm and the other L 72 cm; sink in glossy Ceramilux art. PIPER1, BIKAPPA tap art. BK200N.*





Mobile in essenza L 144 cm, P 54 cm, H 25 cm, art. LB12144, composto da tre cassetti, due di L 36 cm e uno di 72 cm. Il top in Flumood H 12,5 cm è in finitura Satin, art. BCS54; lavabo in Ceramilux lucido art. SERVORETTO50. La rubinetteria è della collezione AYATI art. AY200SA finitura satinata. Specchio art. FLASH90W L 144 cm, H 90 cm.

*Cabinet in wood essence L 144 cm, P 54 cm, H 25 cm, art. LB12144 with three drawers, two are L 36 cm and one is L 72 cm. The top is in Flumood H 12,5 cm in the Satin finish, art. BCS54; sink in glossy Ceramilux art. SERVORETTO50. Ayati tap art. AY200SA in a satin finish. Mirror art. FLASH90W L 144 cm, H 90 cm.*







PLANETA

Composizione con due pensili laccati Grigio Smog opaco L 54 cm, H 50 cm, P 14 cm art. LE154. Specchio art. FLASH50W L 180 cm. Il top è in Corian L 180 cm P 54 cm H 12,5 cm art. CRS54 con doppio lavabo integrato art. MYSLOT72. La rubinetteria collezione AYATI art. AY301SA in finitura acciaio satinato, il sifone art. MICRO e gli accessori della collezione TAPE sono tutti in acciaio AISI 304 finitura satinata. La base sospesa L 144 cm, H 37,5 cm, P 54 cm è l'art. LI4144.

*Composition with two lacquered wall cabinets color matt Grigio Smog L 54 cm, H 50 cm and D 14 cm art. LE154. Mirror art. FLASH50W L 180 cm. The top is in Corian L 180 cm, D 54 cm, H 12,5 cm art. CRS54 with double integrated sinks art. MYSLOT72. The AYATI tap collection art. AY301SA in satin stainless steel, the siphon art. MICRO and the TAPE accessories are all in steel AISI 304 in a satin finish. The hanging cabinet L 144 cm, H 37,5 cm, D 54 cm is art. LI4144.*



Lo specchio è un art. FLASH50W di lunghezza speciale 225 cm, H 50 cm. Rubinetteria BIKAPPA art. BK200N; mobile in Rovere moro art. LA64180 versione destra in larghezza speciale di 225 cm, P 54 cm, H 50 cm. Il top art. LT2 lunghezza speciale 225 cm, P 54 cm, H 12 mm, è in vetro acidato Nero. I lavabi sono due art. PIPER1 in Ceramilux lucido.

*The mirror is art. FLASH50W in a custom length 225 cm, H.50 cm. BIKAPPA tap art. BK200N: cabinet in Rovere moro art. LA64180 right version in a custom length 225 cm, D 54 cm, H 50 cm. The top is art. LT2 also in a custom length 225 cm, D 54 cm and 12 mm thick in acid etched Nero lacquered glass. The two sinks are art. PIPER1 in Ceramilux glossy.*









I pensili sono quattro art. LE4245 versione destra, L 45 cm, P 22 cm, H 100 cm ciascuno. La base a terra è composta dall'art. LA58180 Bianco opaco, L 180 cm, P 54 cm, H 50 cm e da uno zoccolo art. LZ54, H 5 cm. Sulla destra un camino a bioetanolo CANTO DEL FUOCO art. CANTOMC270 con cinque bruciatori art. LAFLACA, due lavabi da terra art. TUBA3 verniciati esternamente in nero gofrato, con rubinetti da terra BIKAPPA art. BK902N.

*The wall cabinets are four art. LE4245 right version, L 45 cm, D 22 cm, H 100 cm each. The composition below is made up of art. LA58180 lacquered matt Bianco, L 180 cm, D 54 cm, H 50 cm with plinth art. LZ54, H 5 cm. On the right hand side a bioethanol fireplace CANTO DEL FUOCO art. CANTOMC270 with five burners art. LAFLACA, two freestanding sinks art. TUBA3 externally lacquered embossed Nero with freestanding BIKAPPA tap art. BK902N.*

Prof. 40/47/54

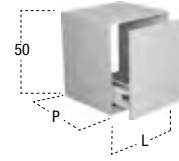
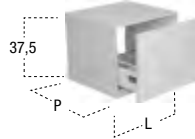
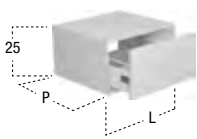

H	L
25	36 / 45 / 54 / 72 / 90 / 108
37,5	36 / 45 / 54 / 72 / 90 / 108
50	36 / 45 / 54 / 72 / 90 / 108

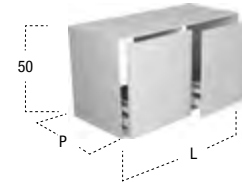
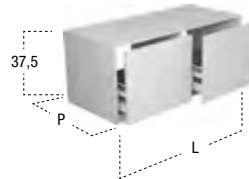
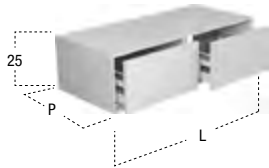

H	L
25	72 (36+36) / 90 (45+45) / 108 (54+54) / 144 (72+72) / 180 (90+90) / 216 (108+108)
37,5	72 (36+36) / 90 (45+45) / 108 (54+54) / 144 (72+72) / 180 (90+90) / 216 (108+108)
50	72 (36+36) / 90 (45+45) / 108 (54+54) / 144 (72+72) / 180 (90+90) / 216 (108+108)

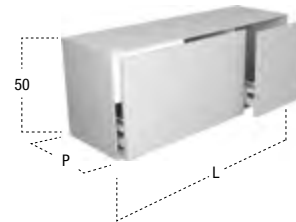
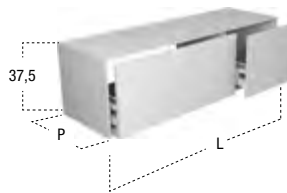

H	L
25	108 (72+36) / 126 (72+54) / 135 (90+45) / 144 (90+54) / 144 (108+36) / 162 (90+72) / 162 (108+54)
37,5	108 (72+36) / 126 (72+54) / 135 (90+45) / 144 (90+54) / 144 (108+36) / 162 (90+72) / 162 (108+54)
50	108 (72+36) / 126 (72+54) / 135 (90+45) / 144 (90+54) / 144 (108+36) / 162 (90+72) / 162 (108+54)

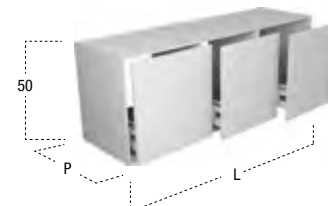
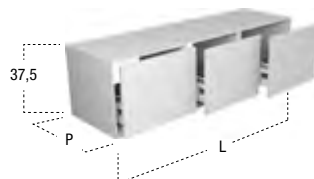
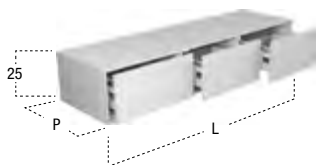

H	L
25	108 (36+36+36) / 135 (45+45+45) / 162 (54+54+54) / 216 (72+72+72)
37,5	108 (36+36+36) / 135 (45+45+45) / 162 (54+54+54) / 216 (72+72+72)
50	108 (36+36+36) / 135 (45+45+45) / 162 (54+54+54) / 216 (72+72+72)

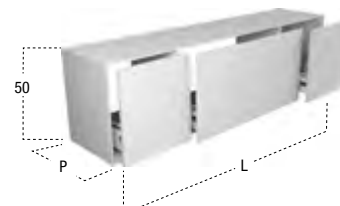
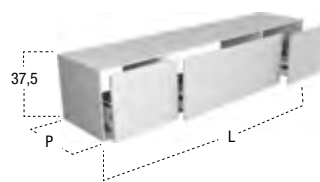
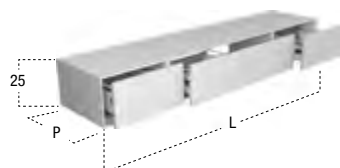

H	L
25	144 (36+72+36) / 162 (36+90+36) / 180 (45+90+45)
37,5	144 (36+72+36) / 162 (36+90+36) / 180 (45+90+45)
50	144 (36+72+36) / 162 (36+90+36) / 180 (45+90+45)

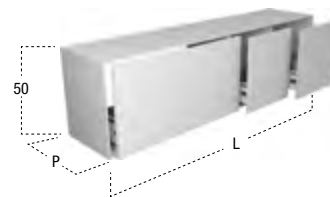
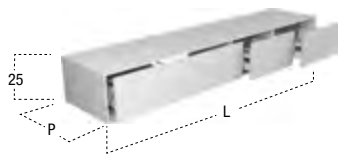

H	L
25	144 (72+36+36) / 162 (90+36+36) / 180 (90+45+45) / 180 (108+36+36) / 216 (108+54+54)
37,5	144 (72+36+36) / 162 (90+36+36) / 180 (90+45+45) / 180 (108+36+36) / 216 (108+54+54)
50	144 (72+36+36) / 162 (90+36+36) / 180 (90+45+45) / 180 (108+36+36) / 216 (108+54+54)

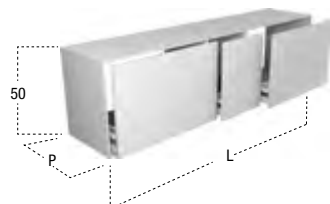
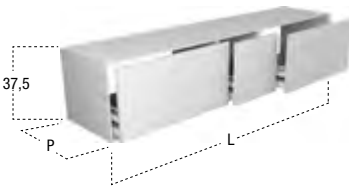
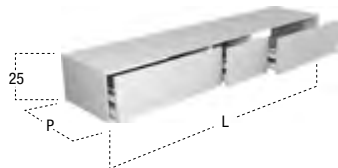

H	L
25	180 (72+36+72) / 216 (90+36+90)
37,5	180 (72+36+72) / 216 (90+36+90)
50	180 (72+36+72) / 216 (90+36+90)

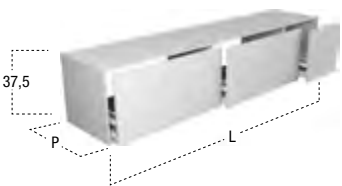
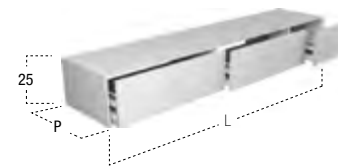

H	L
25	180 (72+72+36) / 216 (90+90+36)
37,5	180 (72+72+36) / 216 (90+90+36)
50	180 (72+72+36) / 216 (90+90+36)

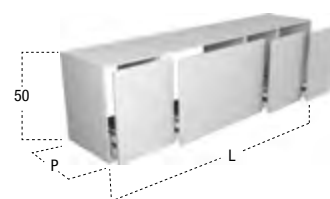
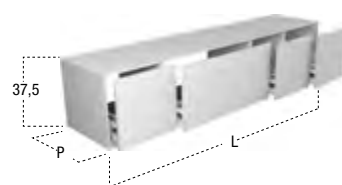
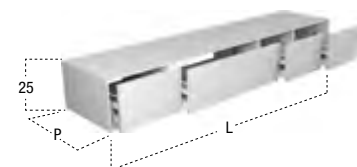

H	L
25	180 (36+72+36+36) / 216 (36+108+36+36)
37,5	180 (36+72+36+36) / 216 (36+108+36+36)
50	180 (36+72+36+36) / 216 (36+108+36+36)

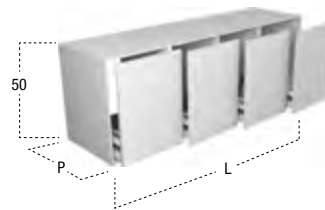
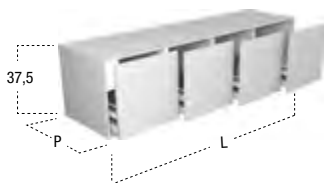

H	L
25	144 (36+36+36+36) / 180 (45+45+45+45) / 216 (54+54+54+54)
37,5	144 (36+36+36+36) / 180 (45+45+45+45) / 216 (54+54+54+54)
50	144 (36+36+36+36) / 180 (45+45+45+45) / 216 (54+54+54+54)

# PLANETA

Prof. 40/47/54

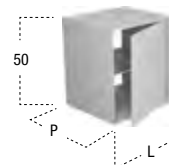
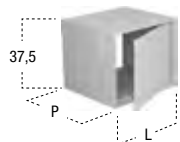
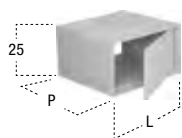

H	L
25	27 / 36 / 45 / 54
37,5	27 / 36 / 45 / 54
50	27 / 36 / 45 / 54

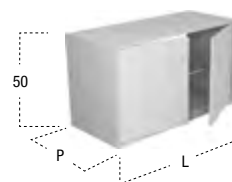
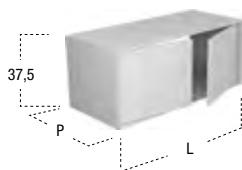
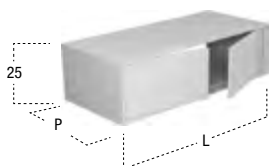

H	L
25	54 (27+27) / 72 (36+36) / 90 (45+45) / 108 (54+54)
37,5	54 (27+27) / 72 (36+36) / 90 (45+45) / 108 (54+54)
50	54 (27+27) / 72 (36+36) / 90 (45+45) / 108 (54+54)

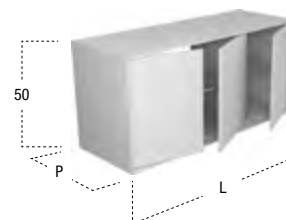
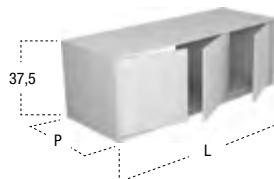
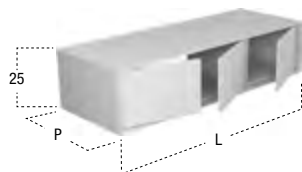

H	L
25	81 [54(27+27)+27] / 108 [72(36+36)+36] / 126 [72(36+36)+54] / 126 [90(45+45)+36] / 135 [90(45+45)+45] / 162 [108(54+54)+54]
37,5	81 [54(27+27)+27] / 108 [72(36+36)+36] / 126 [72(36+36)+54] / 126 [90(45+45)+36] / 135 [90(45+45)+45] / 162 [108(54+54)+54]
50	81 [54(27+27)+27] / 108 [72(36+36)+36] / 126 [72(36+36)+54] / 126 [90(45+45)+36] / 135 [90(45+45)+45] / 162 [108(54+54)+54]

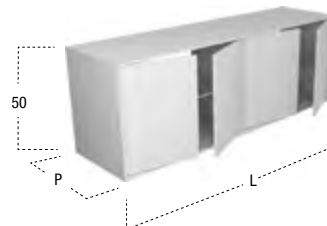
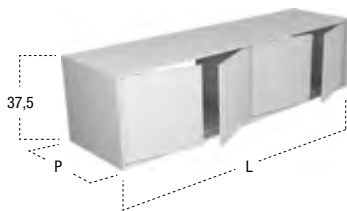
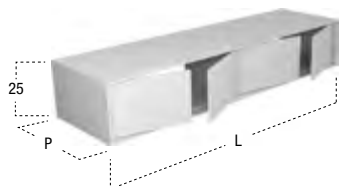

H	L
25	108 [54(27+27)+54(27+27)] / 144 [72(36+36)+72(36+36)] / 180 [90(45+45)+90(45+45)] / 216 [108(54+54)+108(54+54)]
37,5	108 [54(27+27)+54(27+27)] / 144 [72(36+36)+72(36+36)] / 180 [90(45+45)+90(45+45)] / 216 [108(54+54)+108(54+54)]
50	108 [54(27+27)+54(27+27)] / 144 [72(36+36)+72(36+36)] / 180 [90(45+45)+90(45+45)] / 216 [108(54+54)+108(54+54)]

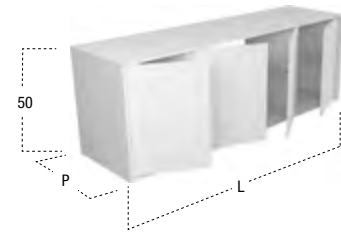
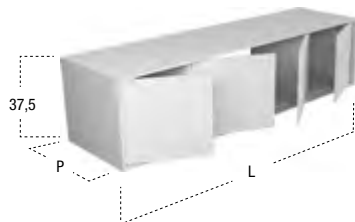
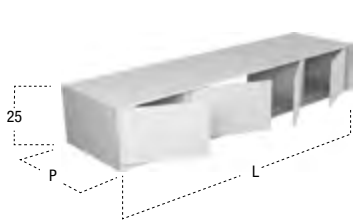

H	L
25	144 [36+72(36+36)+36] / 180 [45+90(45+45)+45] / 216 [54+108(54+54)+54]
37,5	144 [36+72(36+36)+36] / 180 [45+90(45+45)+45] / 216 [54+108(54+54)+54]
50	144 [36+72(36+36)+36] / 180 [45+90(45+45)+45] / 216 [54+108(54+54)+54]

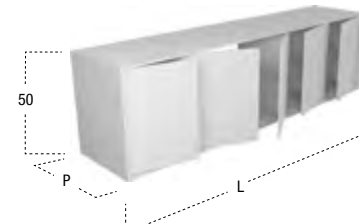
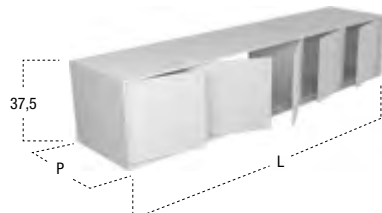
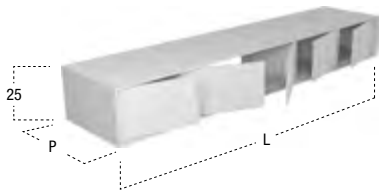

H	L
25	135 [27+54(27+27)+27+27] / 180 [36+72(36+36)+36+36]
37,5	135 [27+54(27+27)+27+27] / 180 [36+72(36+36)+36+36]
50	135 [27+54(27+27)+27+27] / 180 [36+72(36+36)+36+36]

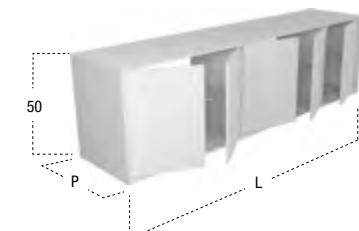
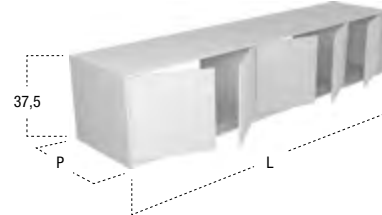
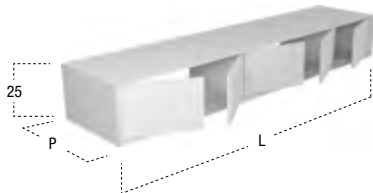

H	L
25	135 [54(27+27)+54(27+27)+27] / 180 [72(36+36)+72(36+36)+36]
37,5	135 [54(27+27)+54(27+27)+27] / 180 [72(36+36)+72(36+36)+36]
50	135 [54(27+27)+54(27+27)+27] / 180 [72(36+36)+72(36+36)+36]

## LUNARIA design Carlo Colombo

Un distacco, pochi centimetri che segnano un inizio e una fine, un cono d'ombra che visivamente separa il mobile dal piano conferendo dinamicità alla composizione.

La gola è protagonista della collezione Lunaria. Una gola che gira tutto attorno al mobile definendone il carattere e facilitando l'apertura delle ante. Uno spazio importante, che crea un distacco visivo tra il mobile e il top soprastante amplificando la sensazione di leggerezza anzi quasi di sospensione. Lavabi e top sembrano lievitare, soprattutto quando un cambio di cromatismo o di materiale accentua la presenza eterea delle superfici.

Una collezione di grande fascino, nella quale un segno distintivo determina un carattere, nella quale la perfezione di un dettaglio identifica uno stile. La discontinuità esalta la capacità di abbinare top e ante differenti, texture ricercate a superfici completamente lucide, materiali luminosi e traslucidi ad altri opachi e materici per trasmettere personalità e identità non solo al mobile ma all'intero spazio bagno.

*A detachment, a few centimeters that mark a beginning and an end, a shadow which visually separates the cabinet from the top granting dynamism to the composition.*

*The top space is the main characteristic of the Lunaria collection. A gorge that runs all around the cabinet facilitating the opening of the doors. An important space, which creates a visual separation between the cabinet and above top amplifying the feeling of lightness rather almost suspended.*

*A collection of great charm, in which a distinctive sign determines the character, in which the perfection of detail identifies a style. The discontinuity enhances the ability to match different tops and doors to convey personality and identity not only to the furniture but to the entire bathroom space.*





LUNARIA



Mobile laccato Terracotta lucido L 216 cm, H 37,5 cm, P 54 cm, art. NI22216; è composto da quattro cassetti, tre L 36 cm e uno L 108 cm. Top in Flumood Texture art. BC154 con lavabo integrato art. PODIO, completo di art. PIANETTO. Rubinetteria AYATI in finitura lucida, composta da art. AY921LU e da art. AY600LU. Specchio art. FLASH75W, L 216 cm, H 75 cm.

*Cabinet lacquered glossy Terracotta L 216 cm, H 37,5 cm, D 54 cm, art. NI22216; is made up of four drawers, three are L 36 cm and one is L 108 cm. Top in Flumood Texture art. BC154 with integrated sink art. PODIO complete with drain cover art. PIANETTO. AYATI tap series in a polished finish art. AY921LU and art. AY600LU. Mirror art. FLASH75W, L 216 cm, H 75 cm.*



Attrezzatura interna STRATO in vetro fumé.

STRATO, internal drawer accessory in fumé glass.



Mobile laccato Matita opaco L 180 cm, H 37,5 cm, P 54 cm, art. NI22180. Top in Corian art. CR154, con lavabo in Ceramilux lucido art. FOGLIO63; la rubinetteria AYATI in finitura satinata è composta da art. AY921SA e art. AY600SA. Accessori della collezione TAPE. La composizione comprende uno specchio art. FLASH100W L 180 cm, H 50 cm.

*Cabinet lacquered matt Matita L 180 cm, H 37,5 cm, D 54 cm art. NI22180. Corian top art. CR154 with Ceramilux glossy sink art. FOGLIO63; AYATI tap series in satin finish art. AY921SA and art. AY600SA. Accessories from the TAPE series. The composition includes also mirror art. FLASH100W L 180 cm, H 50 cm.*



LUNARIA



Camino della collezione CANTO DEL FUOCO art. CANTOMC63 con bruciatore a bioetanolo art. LAFLACA.

Fireplace from the CANTO DEL FUOCO collection art. CANTOMC63 with bioethanol burner art. LAFLACA.



LUNARIA

Box doccia art. PENISOLA88 in vetro extrachiaro con distanziale in acciaio inox satinato AISI 304; piatto doccia art. OX88,5COMBI L 173,5 cm, doghe removibili in Corian, con possibilità di essere installato in appoggio o incassato a pavimento. La rubinetteria collezione AYATI in finitura satinata art. AY150SA e art. AY652RSA. Appendi abiti in acciaio satinato art. BILLO.

*Shower enclosure art. PENISOLA88 in extraclear glass with satin stainless steel support bar AISI 304; shower tray art. OX88,5COMBI L 173,5 cm in Corian with removable slates and possibility of being installed above or flush with the floor. AYATI taps art. AY150SA and AY652RSA. Clothes hook in satin stainless steel art. BILLO.*







Mobile in essenza legno Rovere naturale L 180 cm, H 50 cm, P 54 cm, art. NA58180 con quattro ante di uguale grandezza; top in Corian art. CR154 con lavabi integrati art. MYSLOT72. La rubinetteria della collezione AYATI è in finitura satinata art. AY301SA. Specchio art. FLASH100W di L 180 cm, H 100 cm.

*Cabinet in wood essence Rovere naturale L 180 cm, H 50 cm, D 54 cm, art. NA58180 with four doors each measuring L 45 cm; top in Corian art. CR154 with integrated sink art. MYSLOT72. AYATI tap in satin stainless steel art. AY301SA. Mirror art. FLASH100W L 180 cm, H 100 cm.*





Modulo centro stanza L 45 cm, H 85,5 cm, P 45 cm, con due ante: una posteriore e una anteriore, art. BLOKKO11; finitura essenza Rovere naturale, all'interno un ripiano in legno. Il mobile è completo di lavabo in Marmo Carrara. La rubinetteria da soffitto art. BK909N, della collezione BIKAPPA è in finitura lucida. Lo specchio è l'art. DAMONE, L 180 cm, H 220 cm.

*Freestanding cabinet L 45 cm, H 88,5 cm, D 45 cm with two doors: front and retro art. BLOKKO11; wood essence Rovere naturale, one internal wood shelf. The cabinet comes complete with a Marmo Carrara sink. Ceiling hung tap art. BK909N from the BIKAPPA series in a polished finish. Mirror art. DAMONE L 180 cm H 220 cm.*

# LUNARIA design Carlo Colombo

Prof. 40/47/54

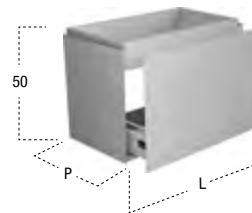
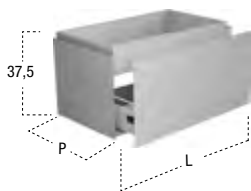

H	L
37,5	54 / 72 / 90 / 108
50	54 / 72 / 90 / 108

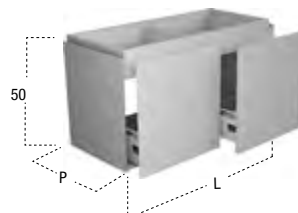
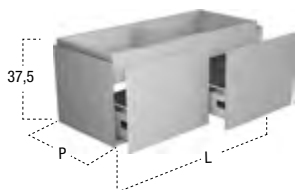

H	L
37,5	72 (36+36) / 90 (45+45) / 108 (54+54) / 144 (72+72) / 180 (90+90) / 216 (108+108)
50	72 (36+36) / 90 (45+45) / 108 (54+54) / 144 (72+72) / 180 (90+90) / 216 (108+108)

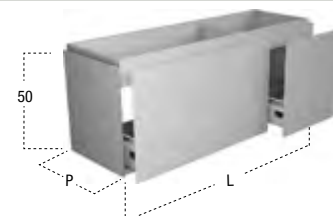
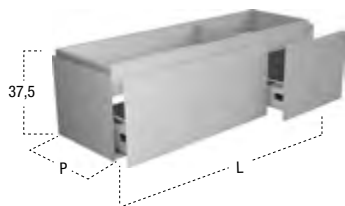

H	L
37,5	108 (72+36) / 126 (72+54) / 135 (90+45) / 144 (90+54) / 144 (108+36) / 162 (90+72) / 162 (108+54)
50	108 (72+36) / 126 (72+54) / 135 (90+45) / 144 (90+54) / 144 (108+36) / 162 (90+72) / 162 (108+54)

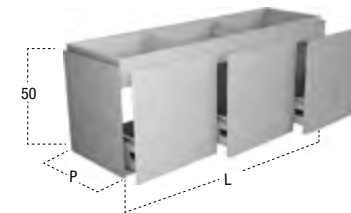
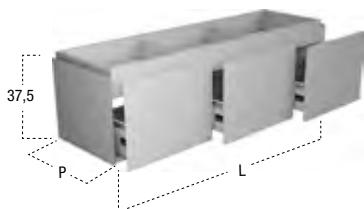

H	L
37,5	108 (36+36+36) / 135 (45+45+45) / 162 (54+54+54) / 216 (72+72+72)
50	108 (36+36+36) / 135 (45+45+45) / 162 (54+54+54) / 216 (72+72+72)

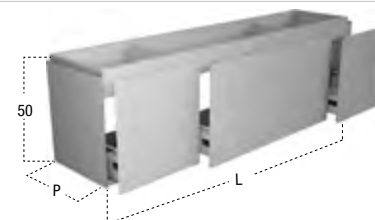
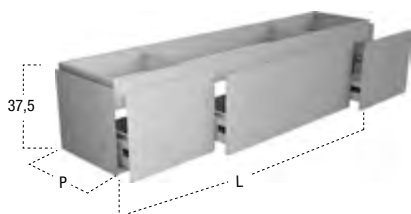

H	L
37,5	144 (36+72+36) / 162 (36+90+36) / 180 (45+90+45) / 180 (36+108+36) / 216 (54+108+54)
50	144 (36+72+36) / 162 (36+90+36) / 180 (45+90+45) / 180 (36+108+36) / 216 (54+108+54)

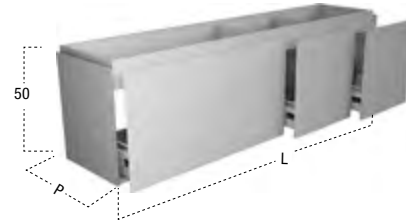
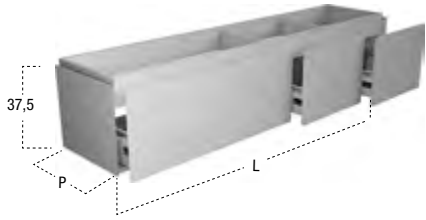

H	L
37,5	144 (72+36+36) / 162 (90+36+36) / 180 (90+45+45) / 180 (108+36+36) / 216 (108+54+54)
50	144 (72+36+36) / 162 (90+36+36) / 180 (90+45+45) / 180 (108+36+36) / 216 (108+54+54)

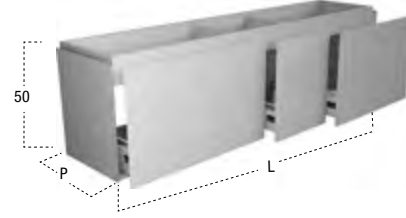
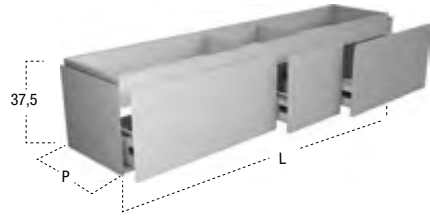

H	L
37,5	180 (72+36+72) / 216 (90+36+90)
50	180 (72+36+72) / 216 (90+36+90)

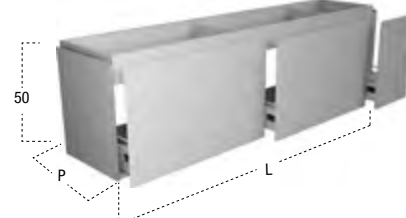
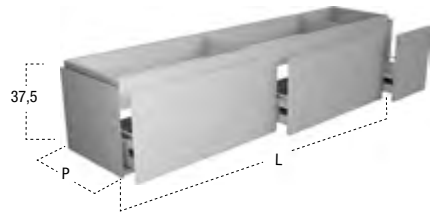

H	L
37,5	180 (72+72+36) / 216 (90+90+36)
50	180 (72+72+36) / 216 (90+90+36)

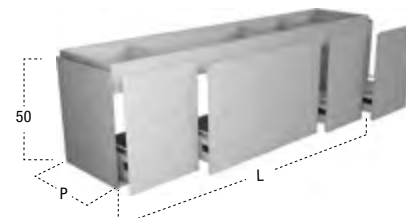
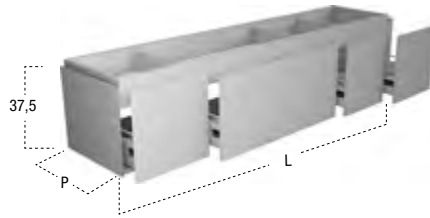

H	L
37,5	180 (36+72+36+36) / 216 (36+108+36+36)
50	180 (36+72+36+36) / 216 (36+108+36+36)

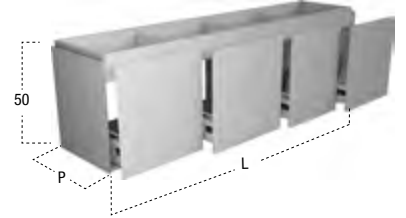
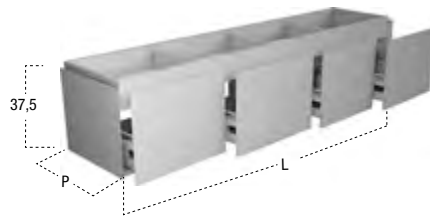

H	L
37,5	144 (36+36+36+36) / 180 (45+45+45+45) / 216 (54+54+54+54)
50	144 (36+36+36+36) / 180 (45+45+45+45) / 216 (54+54+54+54)

# LUNARIA

Prof. 40/47/54

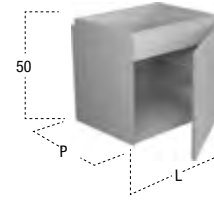
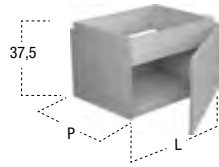

H	L
37,5	27 / 36 / 45 / 54
50	27 / 36 / 45 / 54

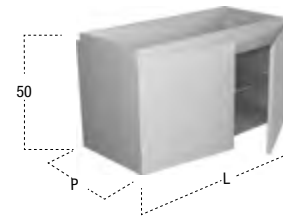
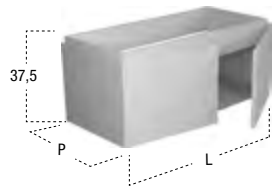

H	L
37,5	54 (27+27) / 72 (36+36) / 90 (45+45) / 108 (54+54)
50	54 (27+27) / 72 (36+36) / 90 (45+45) / 108 (54+54)

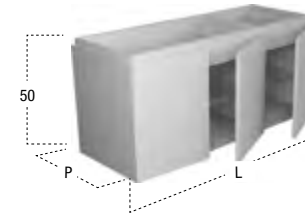
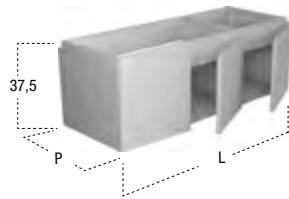

H	L
37,5	81 [54(27+27)+27] / 108 [72(36+36)+36] / 126 [72(36+36)+54] / 126 [90(45+45)+36] / 135 [90(45+45)+45] / 162 [108(54+54)+54]
50	81 [54(27+27)+27] / 108 [72(36+36)+36] / 126 [72(36+36)+54] / 126 [90(45+45)+36] / 135 [90(45+45)+45] / 162 [108(54+54)+54]

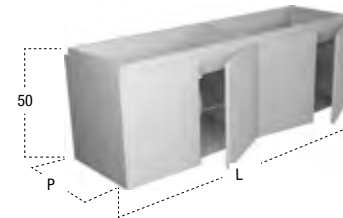
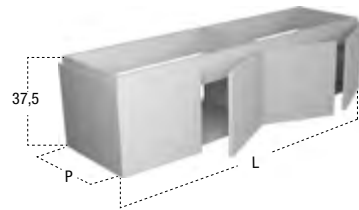

H	L
37,5	108 [54(27+27)+54(27+27)] / 144 [72(36+36)+72(36+36)] / 180 [90(45+45)+90(45+45)] / 216 [108(54+54)+108(54+54)]
50	108 [54(27+27)+54(27+27)] / 144 [72(36+36)+72(36+36)] / 180 [90(45+45)+90(45+45)] / 216 [108(54+54)+108(54+54)]

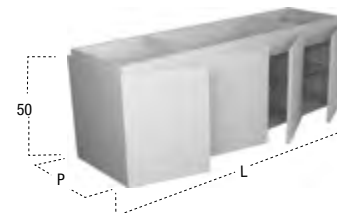
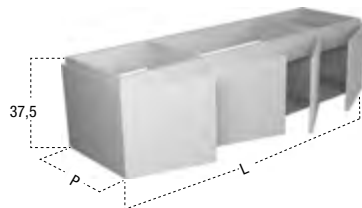

H	L
37,5	144 [36+72(36+36)+36] / 180 [45+90(45+45)+45] / 216 [54+108(54+54)+54]
50	144 [36+72(36+36)+36] / 180 [45+90(45+45)+45] / 216 [54+108(54+54)+54]

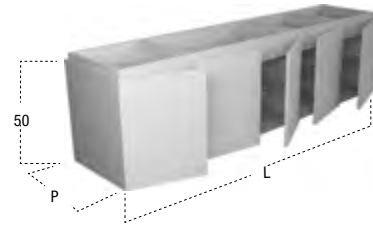
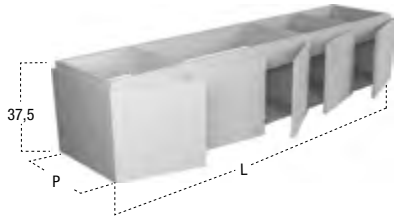

H L

37,5 135 [27+54(27+27)+27+27] / 180 [36+72(36+36)+36+36]

50 135 [27+54(27+27)+27+27] / 180 [36+72(36+36)+36+36]

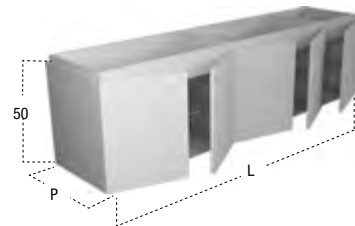
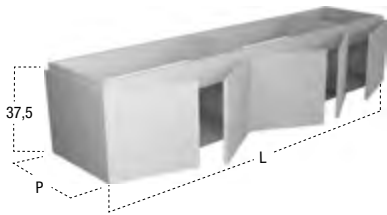

H L

37,5 135 [54(27+27)+54(27+27)+27] / 180 [72(36+36)+72(36+36)+36]

50 135 [54(27+27)+54(27+27)+27] / 180 [72(36+36)+72(36+36)+36]

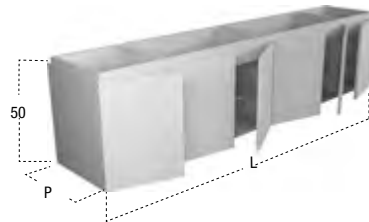
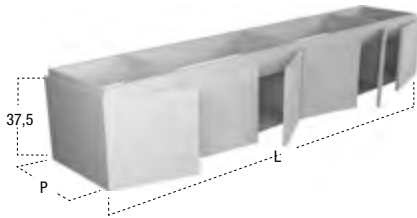

H L

37,5 162 [27+54(27+27)+54(27+27)+27] / 216 [36+72(36+36)+72(36+36)+36]

50 162 [27+54(27+27)+54(27+27)+27] / 216 [36+72(36+36)+72(36+36)+36]

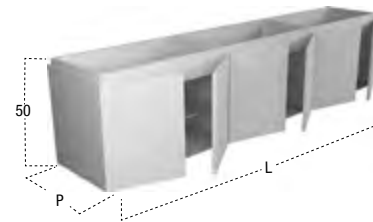
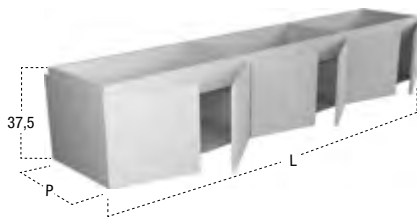

H L

37,5 162 [54(27+27)+54(27+27)+54(27+27)] / 216 [72(36+36)+72(36+36)+72(36+36)]

50 162 [54(27+27)+54(27+27)+54(27+27)] / 216 [72(36+36)+72(36+36)+72(36+36)]

## ILBAGNO design Roberto Lazzeroni

Un progetto dedicato a un'area di gusto molto sofisticata, una rilettura rispettosa delle forme classiche che si traduce in elementi dalle linee morbide ed eleganti.

Una collezione fortemente emozionale caratterizzata dalla matericità delle essenze del legno, dal sapiente uso dei laccati, dal gusto retrò degli specchi, dai riflessi dei metalli: Ilbagno racconta nuovi orizzonti, descrive atmosfere intime e ricercate, è un ritorno alle origini, un progetto che guarda al passato per esplorare il futuro.

Una collezione per un bagno borghese, romantico, una proposta meno rigorosa e minimale che consente di recuperare la memoria di immagini conosciute, gli stilemi di un nobile passato, le suggestioni che vengono da stili diversi. Un'operazione non nostalgica ma quanto mai attuale, una rielaborazione di contenuti ottenuta attraverso la pulizia e lo stile propri di antoniolupi, la cura maniacale dei dettagli, l'eccellenza delle lavorazioni e dei materiali utilizzati.

Mobili, consolle, applique, specchi, accessori, vasche, un vero e proprio progetto di arredo, una collezione fortemente emozionale che, con la matericità delle essenze del legno e il sapiente uso del colore laccato, crea atmosfere intime e ricercate. E' caratterizzata infatti da componenti differenti tra loro per materiali ed estetica, accomunati però da un'unica filosofia che identifica il progetto grazie al gusto romantico di tutti gli elementi; una sofisticata rilettura di forme classiche e di design dalle linee eleganti e morbide.

*A project dedicated to an area of very sophisticated taste, a respectful reinterpretation of classical forms that results in elements with soft and elegant lines.*

*A highly emotional collection characterized by the material nature of the woods, by the skillful lacquering, retro style of the mirrors and the metal reflections: Ilbagno describes an intimate and refined atmosphere with a return to origins, a project that looks to the past to explore the future.*

*A collection for a middle-class bathroom, romantic, a proposal less rigorous and minimal which allows you to recover the memory of familiar images, the style of a noble past, the suggestions that come from different styles. Not nostalgic but rather current, a reworking of content obtained through the antoniolupi style almost maniacal attention to detail, the excellence of the workmanship and materials used.*

*Furniture, consoles, wall lamps, mirrors, accessories, tubs, a real design project, a highly emotional collection with the material nature of wood and the wise use of lacquered color, create an intimate and refined atmosphere. And in fact it's characterized by different components in the material and aesthetic aspects, but united by a single philosophy that identifies the project thanks to the romantic taste of all the elements; a sophisticated reinterpretation of classic forms and design with elegant and soft lines.*







ILBAGNO







Nella foto sopra, vasca in Cristalplant art. SUITE310 verniciata esternamente color Matita gofrato.  
Sullo sfondo il termocamino a legna art. FILOSKEMA75.

*In the picture above the Cristalplant bathtub art. SUITE310 externally lacquered embossed Matita.  
Behind, the fireplace art. FILOSKEMA75.*





Console in Frassino Moka L 108 cm, P 54 cm, H 83,5 cm, art. ACCORDO108, abbinata al top in vetro con lavabo integrato laccato Nero lucido art. ACCORDO2108. Nella foto a destra la console è in Noce Americano, lo specchio è un art. LUXOR775 L 75 cm, H 75 cm, con cornice in vetro bronzo.

*Console in Frassino Moka L 108 cm, D 54 cm, H 83,5 cm, art. ACCORDO108, combined with glass top and integrated sink lacquered Nero art. ACCORDO2108. The picture on the right has a console in Noce Americano, the mirror art. LUXOR775 L 75 cm, H 75 cm with bronze glass.*



ILBAGNO









Consolle in massello Noce Americano, art. ACCORDO180, abbinata al top in Cristalplant con lavabi integrati art. ACCORDO1180. Gli specchi art. FORMA54 di L 54 cm e H 85 cm, hanno una cornice in legno massello Noce Americano. Lampade in vetro bronzo soffiato art. RONDO1.

*Solid Noce Americano console art. ACCORDO180 combined with top in Cristalplant and integrated sink art. ACCORDO1180. The mirrors art. FORMA54 L 54 cm and H 85 cm have a frame in solid Noce Americano. Lamps in bronze colored blown glass art. RONDO1.*



ILBAGNO



Console in massello Frassino Moka, art. ACCORDO180M, abbinata al top in Cristalplant con lavabi integrati art. ACCORDO1180. Gli specchi art. FORMA54 di L 54 cm e H 85 cm, hanno una cornice in legno massello Frassino Moka, sono illuminati dalle lampade in vetro bronzo soffiato art. RONDO1.

*Console in solid Frassino Moka art. ACCORDO180M is combined with a Cristalplant top and integrated sinks art. ACCORDO1180. The mirrors art. FORMA54 L 54 cm and H 85 cm have a solid Frassino Moka frame, they are illuminated by lamps in blown glass art. RONDO1. The tap is from the TIMBRO collection in polished chrome art. TB230 and MICRO siphon also in polished chrome.*





Consolle in massello Noce Americano, art. ACCORDO180M, abbinata al top in Cristalplant con lavabi integrati art. ACCORDO1180. Gli specchi art. FORMA54 di L 54 cm e H 85 cm, hanno una cornice in legno massello Noce Americano, sono illuminati dalle lampade in vetro bronzo soffiato art. ROND01.

Nella foto a destra la vasca in Cristalplant art. SUITE310.

*Console in solid Noce Americano art. ACCORDO180M is combined with a Cristalplant top and integrated sinks art. ACCORDO1180. The mirrors art. FORMA54 L 54 cm and H 85 cm have a solid Noce Americano frame, they are illuminated by lamps in blown glass art. ROND01.*

*In the picture on the right, tub in Cristalplant art. SUITE310.*



ILBAGNO







ILBAGNO



Nella foto a destra, consolle in Noce Americano art. ARMONIA108, con top in Ceramilux lucido con lavabo integrato art. ARMONIA1108. Ai lati dello specchio, art. LUXOR475, le lampade in vetro bronzo soffiato art. RONDO1.

*On the right, console in Noce Americano art. ARMONIA108 with top in glossy Ceramilux and integrated sink art. ARMONIA1108. To the sides of the mirror art. LUXOR475 the lamps in bronze colored blown glass art. RONDO1.*











Il mobile laccato color Havana lucido, è composto da un basamento in Frassino Moka comprensivo di fianchi art. PIANO154, da due basi art. GBB236 L 36 cm, da un porta lavabo art. GBL272 L 72 cm e da un top in marmo Calacatta Oro art. TEMPO354 L 162 cm; il lavabo sopra-piano è in Ceramilux lucido art. BOLO63. Lo specchio, con cornice in vetro argentato fumè art. LUXOR9126 di L 126 cm e H 75 cm è illuminato dalle lampade in vetro bronzo soffiato art. RONDO1.

*The furniture lacquered glossy Havana is made up of a base in Frassino Moka inclusive of sides art. PIANO154, two cabinets art. GBB236 L 36 cm, one sink unit art. GBL272 L 72 cm, and a top in marble Calacatta Oro art. TEMPO354; top mount sink in glossy Ceramilux art. BOLO63. The mirror with silvered fumè glass art. LUXOR9126, L 126 cm and H 75 cm illuminated by two lamps in blown glass art. RONDO1.*







ILBAGNO









Il mobile laccato Biancospino lucido è composto da un basamento in Noce Americano art. ALLEGRO254, H 45,5 cm, P 54 cm, da due fianchi art. GIF454 L 18 cm, da due basi art. GIB236 L 36 cm, da un porta lavabo art. GIL272, L 72 cm e da un top con lavabo integrato in Cristalplant art. TEMPO1472. L'intera composizione è H 84 cm P 54 cm. Lo specchio ha la cornice in vetro argentato rosè art. LUXOR790 L 90 cm e H 90 cm.

*The glossy lacquered cabinet in color Biancospino is made up of a base in Noce Americano art. ALLEGRO254, H 45,5 cm, P 54 cm, two side panels art. GIF454 L 18 cm, two cabinets art. GIB236 L 36 cm, sink unit art. GIL272 L 72 cm and a top with integrated sink in Cristalplant art. TEMPO1472. The entire composition is H 84 cm D 54 cm. The mirror in rosè silvered glass frame art. LUXOR790 L 90 cm and H 90 cm.*





Vasca in Cristalplant art. SUITE310.

*Cristalplant bathtub art. SUITE310.*



Il mobile laccato Grigio Smog opaco è composto da una coppia di fianchi art. GIF454 L 18 cm, da due basi art. GIB236 L 36 cm, da un porta lavabo art. GIL272, L 72 cm e da un top in vetro Grigio Smog acidato art. TEMPO254 L 180 cm, P 54, spessore 12 mm. Lo specchio con cornice in vetro argentato fumè è l'art. LUXOR10117, L 117 cm e H 80 cm. Su richiesta è possibile inserire cassetti art. WOOD in Noce Americano.

*The cabinet lacquered in matt Grigio Smog and made up of a pair of side panels art. GIF454 L 18 cm, , two cabinets art. GIB236 L 36 cm, sink unit art. GIL272 L 72 cm and acid etched glass Grigio Smog art. TEMPO254 L 180 cm, D 54, thickness 12 mm. Mirror with smoked glass art. LUXOR10117, L 117 cm H 80 cm. Upon request possible to include drawers art. WOOD in Noce Americano finish.*









ILBAGNO



Il mobile laccato Blu Navy lucido, è composto da un basamento in Frassino Moka comprensivo di fianchi art. PIANO1254, da due porta lavabi art. GIL272 L 72 cm e da una base art. GIB236. Top in marmo Petra Ruja art. TEMPO354 L 198 cm, lavabo sopra piano in Ceramilux lucido art. BOL063. Lo specchio, con cornice in vetro argentato bronzo art. LUXOR775 di L 75 cm e H 75 cm è illuminato dalle lampade in vetro bronzo soffiato art. RONDO1.

*The furniture lacquered glossy Blu Navy is made up of a base in Frassino Moka inclusive of sides art. PIANO1254, two sink units art. GIL272 L 72 cm and one cabinet art. GIB236. Top in marble Petra Ruja art. TEMPO354 L 198 cm with topmount sink in glossy Ceramilux art. BOL063. The mirror with silvered bronze glass art. LUXOR775 L 75 cm and H 75 cm is illuminated by lamps in blown glass art. RONDO1.*







Il mobile sospeso laccato Tortora lucido, è composto da una cornice in Noce Americano art. ADAGIO54, da due fianchi art. GIF454 L 18 cm, da due basi art. GIB236 L 36 cm, da un porta lavabo art. GIL272 L 72 cm e da un top con lavabo integrato in Cristalplant art. TEMPO1472. Lo specchio orizzontale o verticale, con cornice in vetro argentato rosè art. LUXOR9117, L 117 cm, H 75 cm, è illuminato dalle lampade in vetro soffiato color bronzo art. RONDO1. A sinistra, un particolare del top in marmo Calacatta Oro art. TEMPO354 su cui poggia il lavabo in Ceramilux lucido art. BOLO63. Il cassetto è in Noce Americano H 18 cm art. WOOD1854.

*Suspended cabinet lacquered glossy Tortora made up of a frame in Noce Americano art. ADAGIO54, two side panels art. GIF454 L 18 cm, two cabinets art. GIB236 L 36 cm, sink unit art. GIL272 L 72 cm and a Cristalplant top with integrated sink art. TEMPO1472. The mirror can be mounted horizontal or vertical and has a frame in rose silvered glass art. LUXOR9117, L 117 cm and H 75 cm lit by lamps in bronze colored blown glass art. RONDO1. To the left a detail of the marble top in Calacatta Oro art. TEMPO354 with a top mount sink in glossy Ceramilux art. BOLO63. The drawer in Noce Americano H 18 cm art. WOOD1854.*



Nella foto: piede in massello di legno Frassino Moka art. CODA120

*In the photo: solid wood stem in Frassino Moka art. CODA120*

Nella composizione a destra, il mobile laccato Tortora lucido è composto da un basamento in Frassino Moka art. ALLEGRO254, H 45,5 cm, P 54 cm, da due fianchi art. GIF454 L 18 cm, da due basi art. GIB236 L 36 cm, da un porta lavabo art. GIL272, L 72 cm e da un top con lavabo integrato in Cristalplant art. TEMPO1472. L'intera composizione è H 84,4 cm, L 180 cm e P 54 cm. Lo specchio con cornice in vetro argentato rosè art. LUXOR790 L 90 cm e H 90 cm è illuminato dalle lampade art. RONDO1.

*The composition on the right is lacquered glossy Tortora made up of a base in Frassino Moka art. ALLEGRO254, H 45,5 cm, P 54 cm, two side panels art. GIF454 L 18 cm, two cabinets art. GIB236 L 36 cm, sink unit art. GIL272 L 72 cm and a top with integrated sink in Cristalplant art. TEMPO1472. The entire composition is H 84,4 cm, L 180 cm and D 54 cm. The mirror with rosè silvered glass frame art. LUXOR790 L 90 cm and H 90 cm is lit by lamps art. RONDO1.*







Il mobile laccato Grigio Smog opaco è composto da un basamento in Noce Americano art. ALLEGRO154, H 33 cm, P 54 cm, da due fianchi art. GIF454 L 18 cm, da due basi art. GIB236 L 36 cm, da un porta lavabo art. GIL272, L 72 cm e da un top in marmo Petra Ruja art. TEMPO354; il lavabo sopra piano è in Ceramilux lucido art. BOLO63. Lo specchio, con cornice in vetro argentato fumé art. LUXOR10126 di L 126 cm e H 80 cm è illuminato dalle lampade in vetro bronzo soffiato art. RONDO1.

*The furniture lacquered matt Grigio Smog is made up of a base in Noce Americano art. ALLEGRO154, H 33 cm, D 54 cm, two sides art. GIF454 L 18 cm, two cabinets art. GIB236 L 36 cm, one sink unit art. GIL272, L 72 cm and a top in marble Petra Ruja art. TEMPO354; the top mount sink in glossy Ceramilux art. BOLO63. The mirror has a frame in silvered fumé glass art. LUXOR10126 di L 126 cm and H 80 cm illuminated by two lamps in blown glass art. RONDO1.*



ILBAGNO





Il mobile laccato Strada lucido, è composto da un basamento in Noce Americano art. ALLEGRO154, da due fianchi art. GAF354 L 18 cm, da due basi art. GAB236 L 36 cm, da un porta lavabo art. GAL372 L 72 cm e da un top in marmo Petra Ruja art. TEMPO354; il lavabo sottopiano è in Ceramilux lucido art. SERVORETTO63. Lo specchio, con cornice in vetro argentato rosè art. LUXOR890 di L 90 cm e H 90 cm.

A sinistra, particolare del cassetto art. WOOD1854 H 18 cm.

*The cabinet lacquered glossy Strada is made up of a structure in Noce Americano art. ALLEGRO154, two side panels art. GAF354 L 18 cm, two cabinets art. GAB236 L 36 cm, sink unit art. GAL372 L 72 cm and a marble top in Pietra Ruja art. TEMPO354; the undermount sink is in glossy Ceramilux art. SERVORETTO63. The mirror has a frame in rose silvered glass art. LUXOR890 L 90 cm and H 90 cm.*

*To the left a detail of the wooden drawer art. WOOD1854 H 18 cm.*





ILBAGNO







I mobili della misura complessiva di L 108 cm ciascuno, sono realizzati nel colore a campione Cobalto lucido. Ogni mobile è composto da un basamento in massello Noce Americano comprensivo di fianchi art. PIANO154, da un porta lavabo art. GBL290 L 90 cm, da un top in vetro laccato a campione Cobalto lucido art. PAUSA254, il lavabo sopra piano è in Ceramilux lucido art. BOLO45. Lo specchio, con cornice in vetro argentato fumè art. LUXOR890 di L 90 cm e H 90 cm è illuminato dalle lampade in vetro bronzo soffiato art. RONDO1.

*The furniture measuring L 108 cm overall are made in the glossy sample color Cobalto. Each furniture is made up of a base in Noce Americano inclusive of two side panels art. PIANO154, sink unit art. GBL290 L 90 cm, a glass top lacquered sample color Cobalto art. PAUSA254, the top mount sink in glossy Ceramilux art. BOLO45. The mirror has a frame in fume silvered glass art. LUXOR890 L 90 cm and H 90 cm and is lit by lamps in bronze colored blown glass art. RONDO1.*



Il mobile realizzato nel colore a campione Cobalto lucido, è composto da un basamento in massello Noce Americano comprensivo di fianchi art. PIANO254, da due basi art. GIB236, L 36 cm, da un porta lavabo art. GIL272 L 72 cm e da un top con lavabo integrato in Cristalplant, art. TEMPO1472 di L 162 cm. Lo specchio orizzontale o verticale con cornice in vetro argentato blu art. LUXOR9126, L 126 cm e H 75 cm.

*The cabinet lacquered with a sample color glossy Cobalto is made up of a base in Noce Americano inclusive two side panels art. PIANO154, two cabinets art. GIB236 L 36 cm, sink unit art. GIL272 L 72 cm and a Cristalplant top with integrated sink art. TEMPO1472 L 162 cm. The mirror, mounted horizontal or vertical, with frame in blu silvered glass art. LUXO9126 L 126 cm and H 75 cm.*



LEGNI  
*WOODS*



NOCE AMERICANO



FRASSINO MOKA

In fase di ordine indicare il tipo di composizione scegliendo la lettera di riferimento (A1,B1,C1,D1,E1,F1). La composizione dovrà essere completata con top di finitura e lavabi a scelta. Di seguito troverete un esempio esplicativo di come ordinare un mobile appartenente alla soluzione C1.

When ordering, indicate the type of composition by choosing the corresponding reference (A1,B1,C1,D1,E1,F1). The composition must be completed with a finishing top and sink of choice. Following is an example of how to order a configuration referenced C1.

ESEMPIO MOBILE DA ORDINARE - EXAMPLE OF CONFIGURATION TO ORDER

**C1** SOLUZIONE - CONFIGURATION

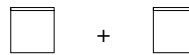
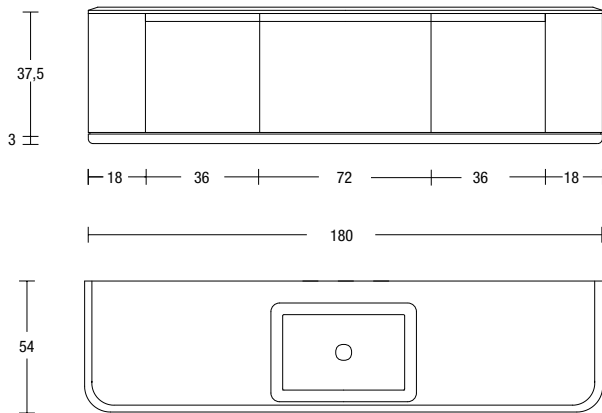

N° 2 ART. GIB236 L 36

Base con 1 cassetto  
Cabinet with 1 drawer

+



ART. GIL272 L 72

Portalavabo con 1 cassetto  
Sink unit with 1 drawer

+



ART. GIF454

Coppia di fianchi con 1 anta e 1 ripiano interno  
Pair of side panels with 1 door and 1 inner shelf

+



ART. ADAGIO54 L 180

Cornice di finitura  
Finishing frame

+

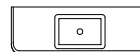

ART. TEMPO1472 L 180

Top con lavabo integrato  
Top with integrated sink

# ILBAGNO

SOLUZIONI CON UN PORTALAVABO E FIANCHI DI 18 CM - CONFIGURATIONS WITH A SINK UNIT AND SIDE PANELS 18 CM

**A1**

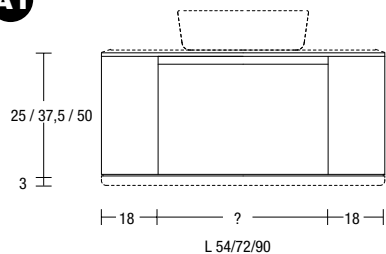

Portlavabo con 1 cassetto  
Sink unit with 1 drawer

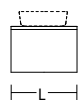

+

Coppia di fianchi a giorno o con 1 anta  
Pair of side panels open or with 1 door



**B1**

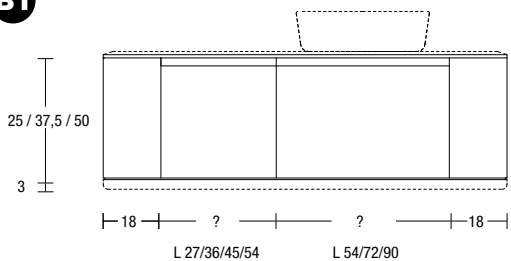

Base con 1 cassetto  
Cabinet with 1 drawer



+

Portlavabo con 1 cassetto  
Sink unit with 1 drawer



+

Coppia di fianchi a giorno o con 1 anta  
Pair of side panels open or with 1 door



**C1**

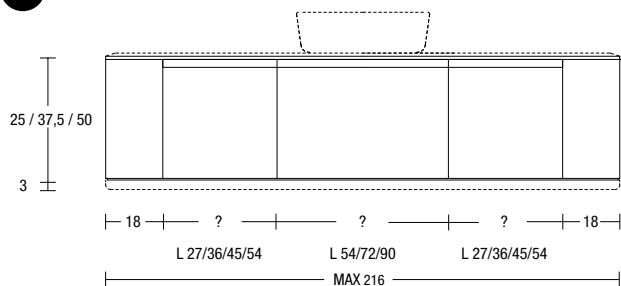

Base con 1 cassetto  
Cabinet with 1 drawer



+

Portlavabo con 1 cassetto  
Sink unit with 1 drawer



+

Base con 1 cassetto  
Cabinet with 1 drawer



+

Coppia di fianchi a giorno o con 1 anta  
Pair of side panels open or with 1 door



SOLUZIONI CON DUE PORTALAVABI E FIANCHI DI 18 CM - CONFIGURATIONS WITH TWO SINK UNITS AND SIDE PANELS 18 CM

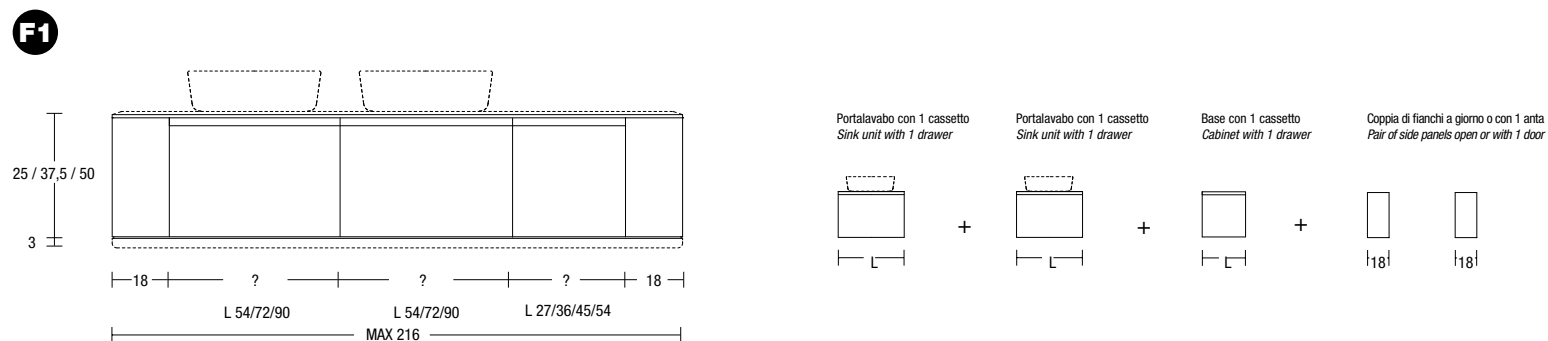
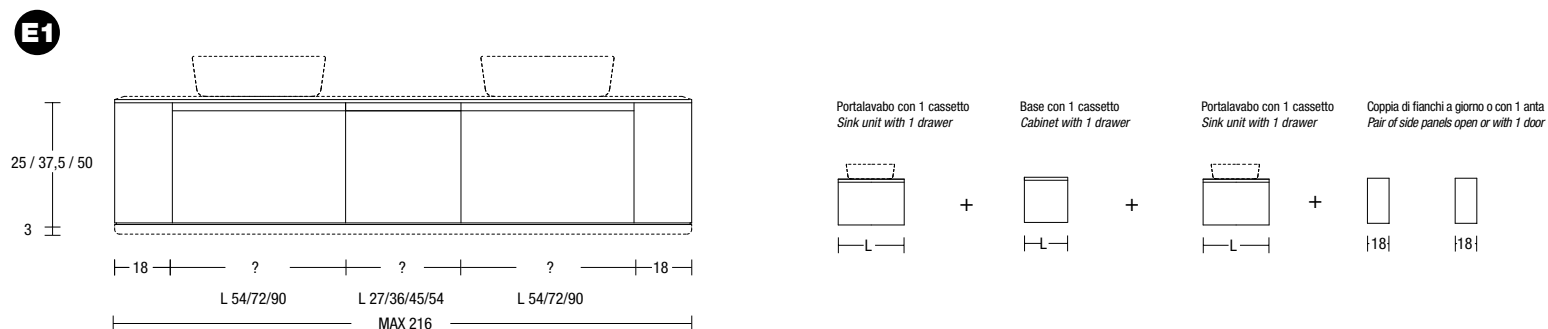
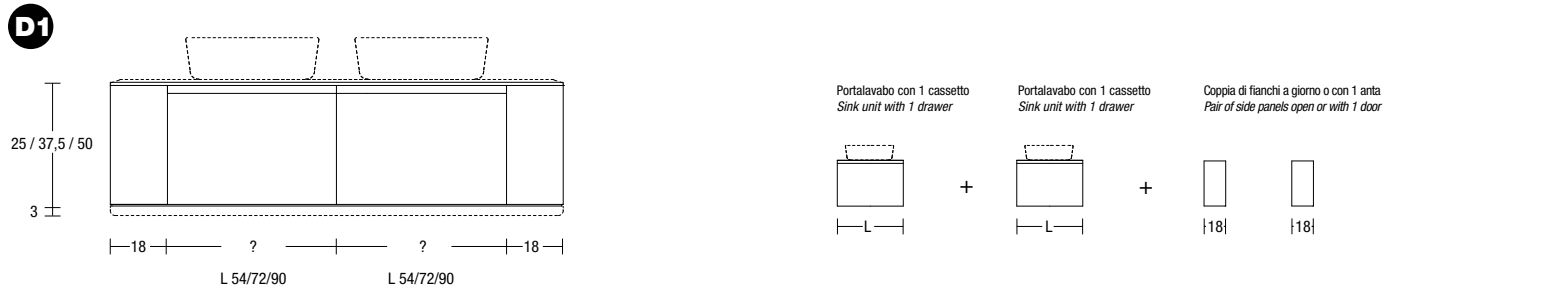

# ILBAGNO

In fase di ordine indicare il tipo di composizione scegliendo la lettera di riferimento (A2,B2,C2,D2,E2,F2). La composizione dovrà essere completata con top di finitura e lavabi a scelta. Di seguito troverete un esempio esplicativo di come ordinare un mobile appartenente alla soluzione C2.

*When ordering indicate the type of composition by choosing the corresponding reference (A2,B2,C2,D2,E2,F2). The composition must be completed with a finishing top and sink of choice. Following is an example of how to order a configuration referenced C2.*

## ESEMPIO MOBILE DA ORDINARE - EXAMPLE OF CONFIGURATION TO ORDER

### **C2** SOLUZIONE - CONFIGURATION

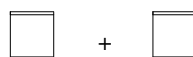
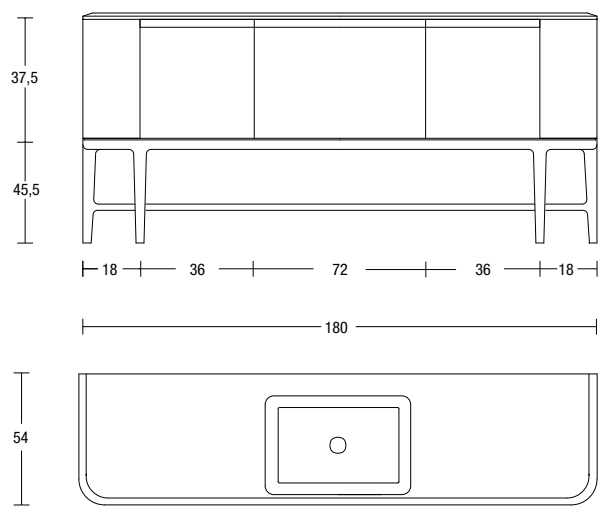

N° 2 ART. GIB236 L 36

Base con 1 cassetto  
Cabinet with 1 drawer

+



ART. GIL272 L 72

Portalavabo con 1 cassetto  
Sink unit with 1 drawer

+



ART. GIF454

Coppia di fianchi con 1 anta e 1 ripiano interno  
Pair of side panels with 1 door and 1 inner shelf

+



ART. ALLEGRO254 L 180

Basamento  
Base

+

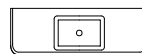

ART. TEMPO1472 L 180

Top con lavabo integrato  
Top with integrated sink



SOLUZIONI CON UN PORTALAVABO E FIANCHI DI 18 CM - CONFIGURATIONS WITH ONE SINK UNIT AND SIDE PANELS 18 CM

**A2**

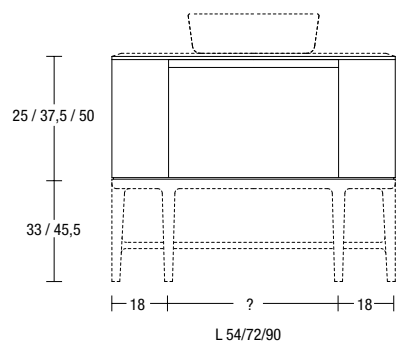

Portlavabo con 1 cassetto  
Sink unit with 1 drawer



+

Coppia di fianchi a giorno o con 1 anta  
Pair of side panels open or with 1 door

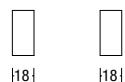

**B2**

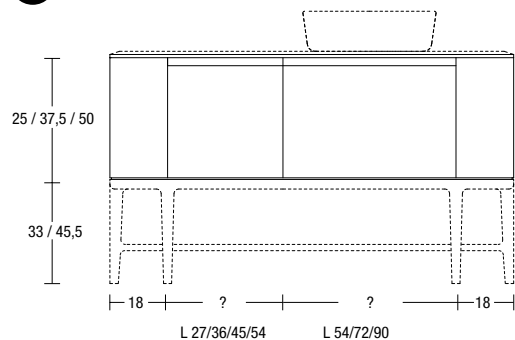

Base con 1 cassetto  
Cabinet with 1 drawer



+

Portlavabo con 1 cassetto  
Sink unit with 1 drawer



+

Coppia di fianchi a giorno o con 1 anta  
Pair of side panels open or with 1 door

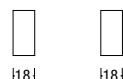

**C2**

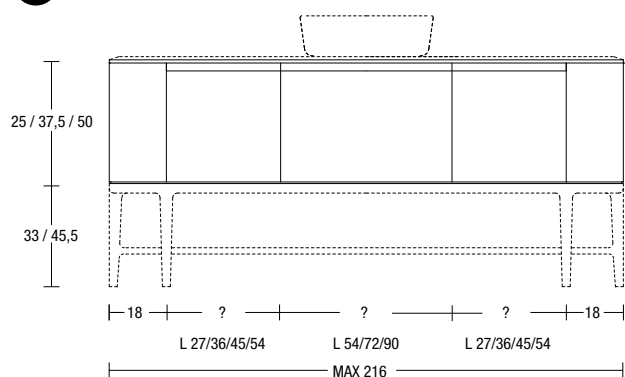

Base con 1 cassetto  
Cabinet with 1 drawer



+

Portlavabo con 1 cassetto  
Sink unit with 1 drawer



+

Base con 1 cassetto  
Cabinet with 1 drawer



+

Coppia di fianchi a giorno o con 1 anta  
Pair of side panels open or with 1 door

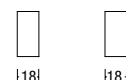

# ILBAGNO

SOLUZIONI CON UN PORTALAVABO E FIANCHI DI 18 CM - CONFIGURATIONS WITH ONE SINK UNIT AND SIDE PANELS 18 CM

**D2**

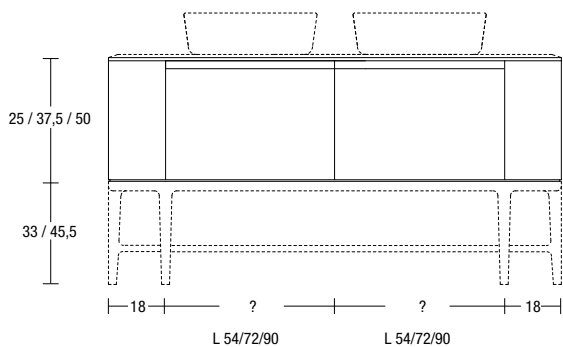

Portalavabo con 1 cassetto  
*Sink unit with 1 drawer*



Portalavabo con 1 cassetto  
*Sink unit with 1 drawer*



Coppia di fianchi a giorno o con 1 anta  
*Pair of side panels open or with 1 door*

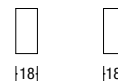

**E2**

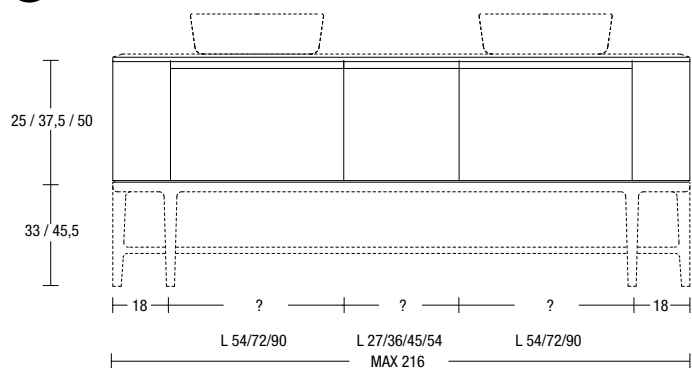

Portalavabo con 1 cassetto  
*Sink unit with 1 drawer*



Base con 1 cassetto  
*Cabinet with 1 drawer*



Portalavabo con 1 cassetto  
*Sink unit with 1 drawer*



Coppia di fianchi a giorno o con 1 anta  
*Pair of side panels open or with 1 door*

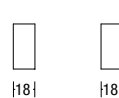

**F2**

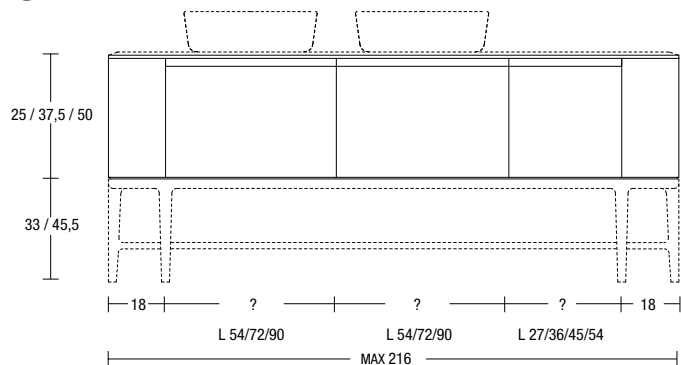

Portalavabo con 1 cassetto  
*Sink unit with 1 drawer*



Portalavabo con 1 cassetto  
*Sink unit with 1 drawer*



Base con 1 cassetto  
*Cabinet with 1 drawer*



Coppia di fianchi a giorno o con 1 anta  
*Pair of side panels open or with 1 door*

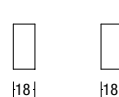

In fase di ordine indicare il tipo di composizione scegliendo la lettera di riferimento (A3,B3,C3,D3,E3,F3). La composizione dovrà essere completata con top di finitura e lavabi a scelta. Di seguito troverete un esempio esplicativo di come ordinare un mobile appartenente alla soluzione C3.

*When ordering indicate the type of composition by choosing the corresponding reference (A3,B3,C3,D3,E3,F3). The composition must be completed with a finishing top and sink of choice. Following is an example of how to order a configuration referenced C3.*

ESEMPIO MOBILE DA ORDINARE - EXAMPLE OF CONFIGURATION TO ORDERCOMMANDER

**C3** SOLUZIONE - CONFIGURATION

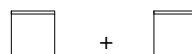
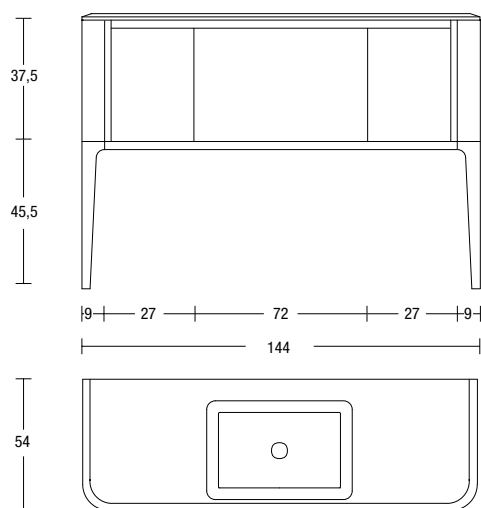

N° 2 ART. GIB227 L 27

Base con 1 cassetto  
Cabinet with 1 drawer

+



ART. GIL272 L 72

Portalavabo con 1 cassetto  
Sink unit with 1 drawer

+

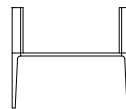

ART. PIANO254 L 144

Basamento comprensivo di fianchi  
Base complete with side panels

+



ART. TEMPO1472 L 144

Top con lavabo integrato  
Top with integrated sink

# ILBAGNO

SOLUZIONI CON UN PORTALAVABO E FIANCHI DI 9 CM - CONFIGURATIONS WITH A SINK UNIT AND SIDE PANELS 9 CM

**A3**

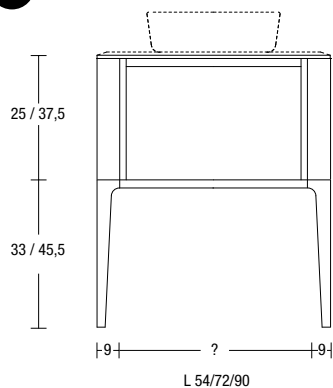

PortLavabo con 1 cassetto  
Sink unit with 1 drawer

Basamento comprensivo di fianchi  
Base complete with side panels

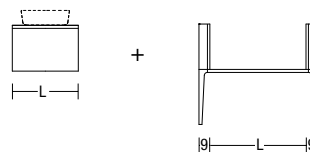

**B3**

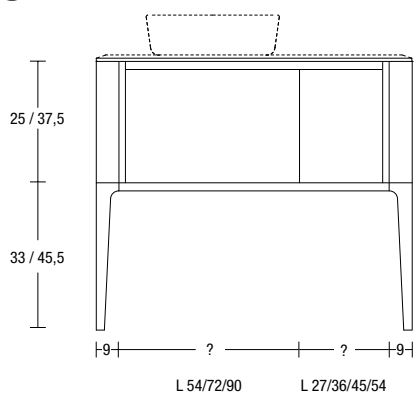

PortLavabo con 1 cassetto  
Sink unit with 1 drawer

Base con 1 cassetto  
Cabinet with 1 drawer

Basamento comprensivo di fianchi  
Base complete with side panels

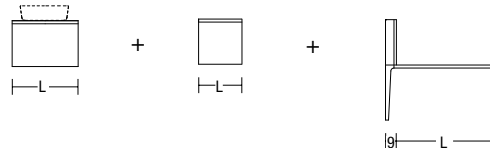

**C3**

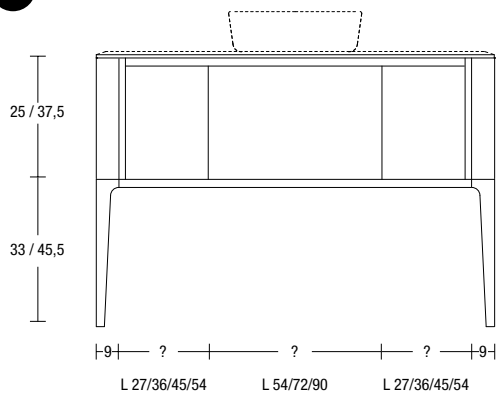

Base con 1 cassetto  
Cabinet with 1 drawer

PortLavabo con 1 cassetto  
Sink unit with 1 drawer

Base con 1 cassetto  
Cabinet with 1 drawer

Basamento comprensivo di fianchi  
Base complete with side panels

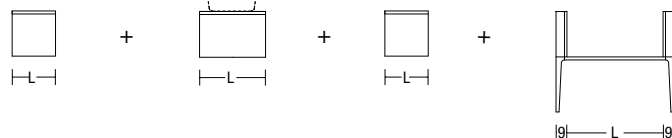

SOLUZIONI CON DUE PORTALAVABI E FIANCHI DI 9 CM - CONFIGURATIONS WITH TWO SINK UNITS AND SIDE PANELS 9 CM

**D3**

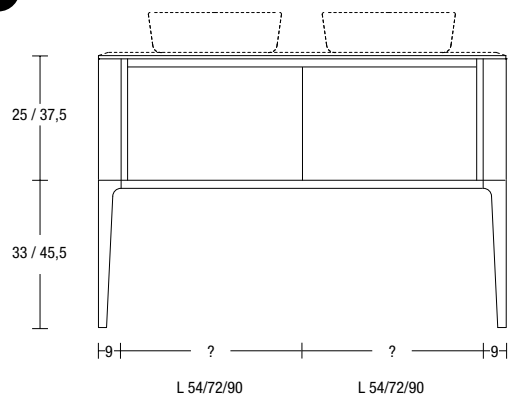

Base con 1 cassetto  
Cabinet with 1 drawer



Portalavabo con 1 cassetto  
Sink unit with 1 drawer



Basamento comprensivo di fianchi  
Base complete with side panels

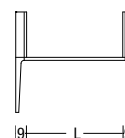

**E3**

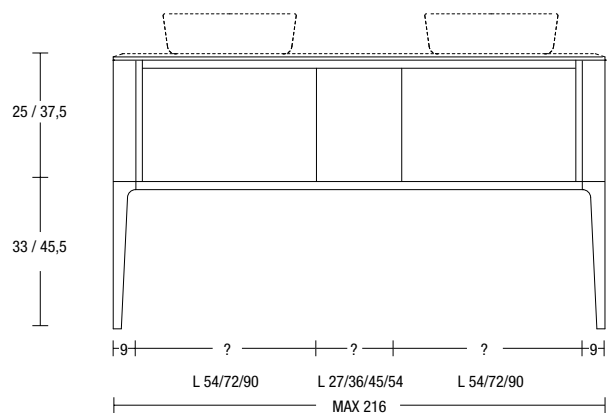

Portalavabo con 1 cassetto  
Sink unit with 1 drawer



Base con 1 cassetto  
Cabinet with 1 drawer



Portalavabo con 1 cassetto  
Sink unit with 1 drawer



Basamento comprensivo di fianchi  
Base complete with side panels

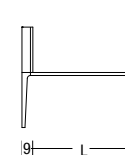

**F3**

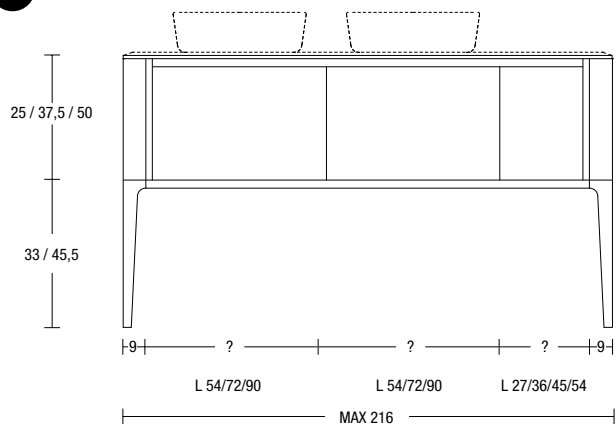

Portalavabo con 1 cassetto  
Sink unit with 1 drawer



Portalavabo con 1 cassetto  
Sink unit with 1 drawer



Base con 1 cassetto  
Cabinet with 1 drawer



Basamento comprensivo di fianchi  
Base complete with side panels

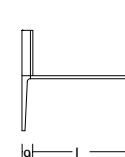

# CARTELLA COLORI

## COLOUR CHART

LEGNO LACCATO, VETRI 8 e 12 mm

### LEGNO LACCATO

Tutte le laccature sono in finitura opaca, goffrata o lucida.

VETRO 8 mm

I top di spessore 8 mm vengono realizzati in vetro laccato o in vetro laccato acidato.

VETRO 12 mm

I top di spessore 12 mm vengono realizzati in vetro laccato o in vetro laccato acidato.

LACQUERED WOOD, GLASS 8 AND 12 mm

### LACQUERED WOOD

All lacquering can be either matt, embossed or glossy.

GLASS 8 mm

Tops 8 mm thick can be produced in lacquered glass or in lacquered acid glass.

GLASS 12 mm

Tops 12 mm thick can be produced in lacquered glass or in lacquered acid glass.



BIANCO MOOD



BIANCOSPINO



OVATTA



MERINGA



BIANCO

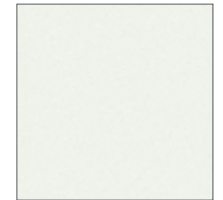

BIANCO VETRO

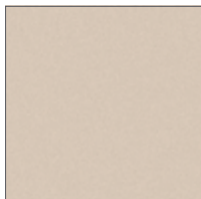

TORTORA

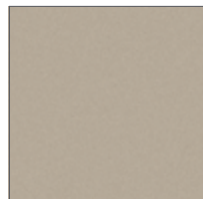

HAVANA

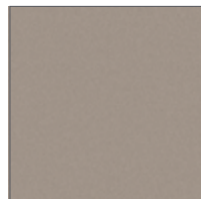

MALTA

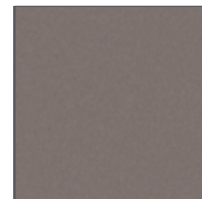

GRIGIO VESUVIO

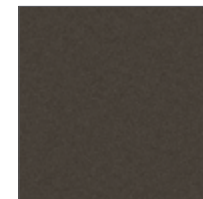

CORTECCIA

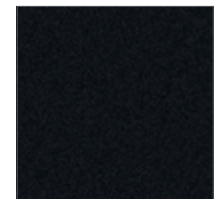

NERO

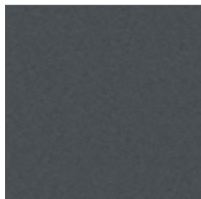

MATITA



STRADA



GRIGIO PIOMBO

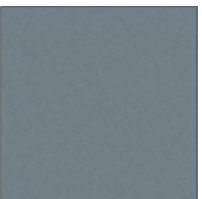

GRIGIO PIOGGIA

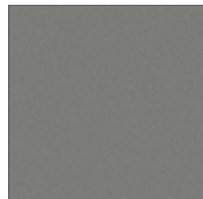

CRETA

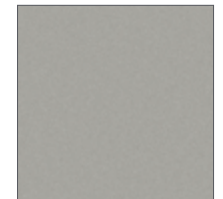

GRIGIO SMOG

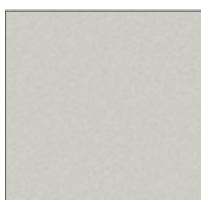

CEMENTO



POMICE

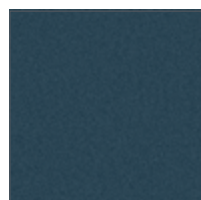

BLU NAVY



MIRTILLO



OSSIDO



CIELO



CIPRIA

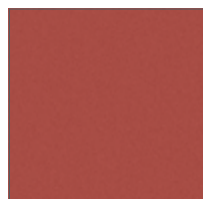

TERRACOTTA

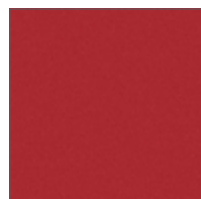

GERANIO



MELOGRANO



MALVA



MOSTARDA



FLORA



NOCE BIONDO



NOCE SBIANCATO



NOCE VISONE



NOCE CANALETTO



ROVERE ARDESIA



ROVERE CASTANO



ROVERE GRIGIO



ROVERE MATITA



ROVERE NATURALE



ROVERE SBIANCATO



ROVERE MORO



ROVERE THERMO



ROVERE EVAPORATO

CARTELLA SOLID SURFACE  
SOLID SURFACE CHART

---

FLUMOOD

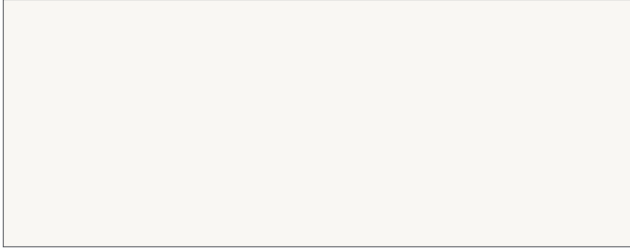

SATIN

TEXTURE

---

QUARZOMOOD

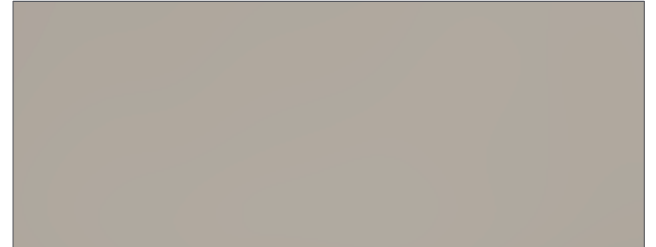
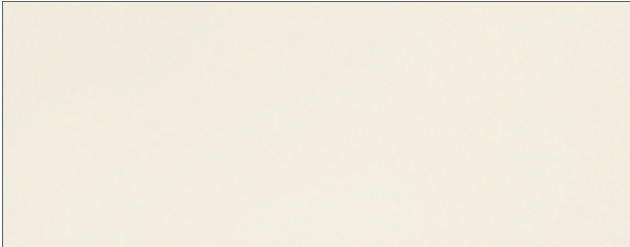

SETA

SERENA

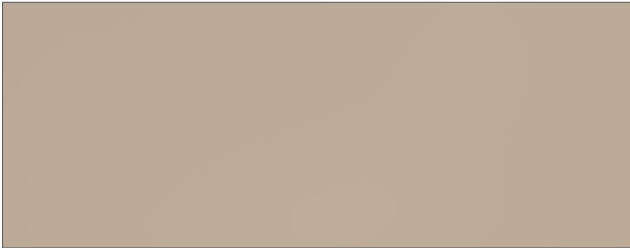

TERRA

---

CORIAN

CRISTALPLANT

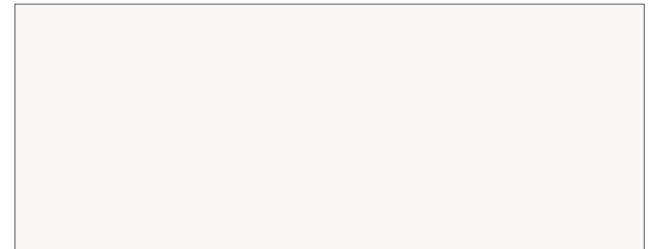
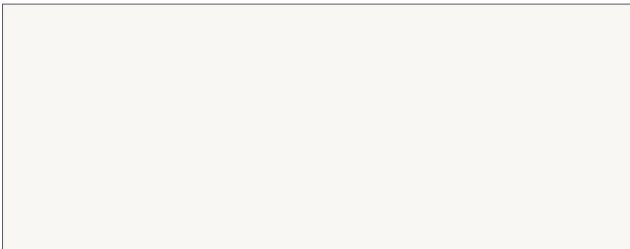

CERAMILUX

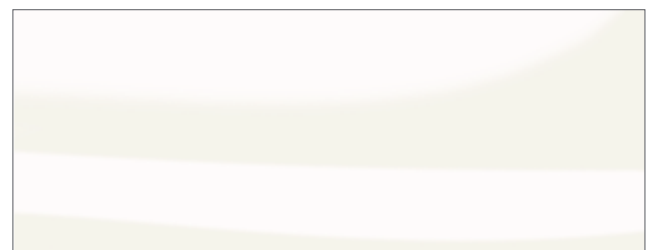
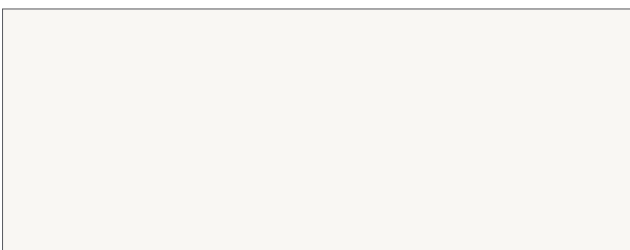

OPACO - MATT

LUCIDO - GLOSSY



MARMI  
MARBLES



MARMO BIANCO CARRARA



MARMO NERO MARQUINIA

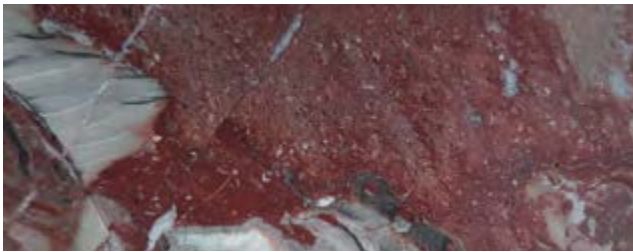

MARMO PETRA RUJA



MARMO CALACATTA ORO



MARMO EMPERADOR

PIETRE  
STONES



PIETRA STONE GREY

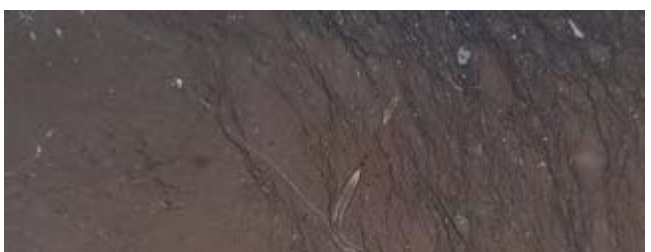

PIETRA VESUVIO



PIETRA SINAI



PIETRA LUNA



PIETRA AMAZZONE

Articoli muniti di lampade a led integrate di classe energetica A non sostituibili

*Articles provided with integrated led bulbs of energy class A not replaceable*

APICE50W	FLASH75W	MODULO872W	NTKIT210W72	SPIO775W	VARIO75W
BATTIGIAL	FLASH90W	MODULO890W	NTKIT210W90	STRAPPOL	VARIO90W
BATTIGIAML	FLASH100W	MODULO8108W	OMBRAL	STRAPPOXLL	VARIO100W
BOLLA	FUORIMETE010	NEULUCE1	PERIPL0	TEATRO15014	VARIO110W
BOLLA2	FUORIMETE020	NEUTRO210W54	SEGRETO	TEATRO15022	VERTICE75W
BSK50W	FUORIMETE020C	NEUTRO210W72	SFOGLIA250	TEATRO25014	VERTICE90W
BSK75W	INTRECCIOL	NEUTRO210W90	SFOGLIA275	TEATRO25022	
BSK90W	LUMEN	NEUTRO1144W45	SFOGLIA290	TEATRO35014	
BSK100W	MANTRA150	NEUTRO1180W45	SFOGLIA2108	TEATRO35022	
BSK110W	MANTRA175	NEUTROLED50W	SFOGLIA75L	TEATRO45014	
BSK210W54	MANTRA190	NEUTROLED75W	SILENZIOL	TEATRO45022	
BSK210W72	MANTRA250	NEUTROLED90W	SOFFIOL	TEATRO17514	
BSK210W90	MANTRA275	NEUTROLED100W	SPIO1W	TEATRO17522	
CALICEL	MANTRA290	NEUTROLED110W	SPIO2W	TEATRO27514	
CIRCUS72W	METE01	NEUTROLED125W	SPIO3W	TEATRO27522	
CIRCUS90W	METE02	NEUTROLED142W	SPIO4W	TEATRO37514	
CIRCUS108W	METE02C	NTKIT50W	SPIO5W	TEATRO37522	
CIRCUS120W	METE03C	NTKIT75W	SPIO150W	TEATRO47514	
CIRCUS140W	METE0_INL	NTKIT90W	SPIO175W	TEATRO47522	
CIRCUS190W	METE0_OUTL	NTKIT100W	SPIO250W	TEATRO10014	
CIRCUS1108W	METE0XLL	NTKIT110W	SPIO275W	TEATRO10022	
FILA75W	MODULO672W	NTKIT125W	SPIO650W	TEATRO12514	
FILA90W	MODULO690W	NTKIT142W	SPIO675W	TEATRO12522	
FLASH50W	MODULO6108W	NTKIT210W54	SPIO750W	VARIO50W	

Articoli venduti con lampade di classe energetica A e compatibili con lampade di classe energetica A++, A+ e A

*Articles sold with bulbs of energy class A and compatible with bulbs of energy classes A++, A+ and A*

RONDÓ1

Articoli venduti con lampade di classe energetica A e compatibili con lampade di classe energetica A, B, C, D, E

*Articles sold with bulbs of energy class A and compatible with bulbs of energy classes A, B, C, D, E*

BOLLA1

Articoli muniti di lampade a led integrate di classe energetica A+ non sostituibili

*Articles provided with integrated led bulbs of energy class A+ not replaceable*

IRIDE  
 LUCENTE45  
 LUCENTE54  
 LUCENTE63  
 LUCENTE72  
 LUCENTE81  
 LUCENTE90  
 LUCENTE99  
 LUCENTE108  
 LUCENTE117  
 LUCENTE126  
 LUCENTE135  
 LUCENTE144  
 LUCENTE153  
 LUCENTE162  
 LUCENTE171  
 LUCENTE180  
 LUCENTE189  
 LUCENTE198  
 LUCENTE207  
 LUCENTE216  
 ZENITLED

Etichette energetiche disponibili su [www.antoniolupi.it](http://www.antoniolupi.it) - Energy labels available on [www.antoniolupi.it](http://www.antoniolupi.it)



**ARCHITETTURA SARTORIALE IN BAGNO**  
***TAILORED ARCHITECTURAL DESIGN IN THE BATHROOM***





**www.antoniolupi.it**

Per essere costantemente informati su novità e prodotti in modo dettagliato, vi invitiamo a navigare nel nostro sito sempre aggiornato. Nell'area download potrete scaricare tutto il materiale tecnico ed informativo che vi necessita.

*To constantly be up to date in a detailed manner on novelties and products please navigate through our website. In the download area you can find all the necessary technical information.*



Scarica l'App su App Store e Google Play per entrare nel mondo antoniolupi

*Download the App on App Store and Google Play to discover the world of antoniolupi*



Prodotto interamente in Italia.

*Entirely made in Italy.*

© Antonio Lupi Design S.p.A. 2018

NOTA: alla Antonio Lupi Design S.p.A. è riservata la facoltà di apportare ai propri modelli qualsiasi modifica estetica, tecnica, nelle dimensioni e nei colori, ritenuta necessaria, nonché la facoltà di sospendere la produzione in qualunque momento senza preavviso, rinunziata fin d'ora da parte del committente ogni conseguente richiesta risarcitoria. Si declina ogni responsabilità relativa ad eventuali inesattezze contenute in questo catalogo, se dovute ad errori di stampa o trascrizioni. Nessun contenuto di questo catalogo può essere copiato, riprodotto anche parzialmente, ripubblicato, trasmesso o distribuito in qualunque forma, senza autorizzazione scritta dell'Antonio Lupi Design S.p.a.

*NOTE: Antonio Lupi Design S.p.A. reserves the right to make any and all necessary esthetic, technical, colour or size modifications in order to enhance use and esthetic value, and may suspend the production cycle at any moment without notice. Such instances may not be subject to claim by the client. We decline all responsibilities for any possible uncertainties due to misprints in this catalogue. None of the material in this catalogue can be copied, reproduced, republished or distributed in any or partial way unless a written authorization is given from the company Antonio Lupi Design S.p.a.*



